

Pixsys

ELECTRONICS



PLC

PL100

Datasheet

1 Acquisition and actuation module PL110	4
1.1 Introduction.....	4
1.2 Front panel and main features	5
1.3 Main hardware features.....	6
1.4 Size and installation	8
1.5 Electrical wirings.....	9
1.5.1 Connectors and terminal blocks.....	9
1.5.2 Connection of sensors to analogue inputs.....	11
1.5.3 Connection of a bidirectional encoder.....	12
1.5.4 Connect PL110 to RS485	12
1.6 Setting dip-switch and rotary-switch.....	13
1.6.1 Setting dip-switches to select COM1 interface	13
1.6.2 Setting dip-switches to select master / slave EXP1	14
1.6.3 Setting PL110-1A protocol address	14
1.6.4 Setting PL110-2A protocol address	15
2 PL110 memory	16
2.1 PL110 memory areas	16
2.1.1 Variables V memory area	17
2.1.2 Memory area "special marker SM".....	17
2.1.3 Memory area "digital inputs I"	40
2.1.4 Memory area "digital outputs Q"	40
2.1.5 Memory area "support marker M"	40
2.1.6 Memory area "analogue inputs AI"	40
2.1.7 Memory area "analogue outputs AQ"	40
2.1.8 Memory area "timer T"	41
2.1.9 Memory area "preset timer PT"	41
2.1.10 Memory area "counters C"	41
2.1.11 Memory area preset values of counters PV.....	41
2.1.12 Memory area EEPROM	41
2.1.13 Memory area MMC	42
2.1.14 Memory areas COMx_Tx and EXP1_Tx	42
2.1.15 Memory areas COMx_Rx and EXP1_Rx.....	42
2.1.16 Memory area display digits	42
3 Modbus RTU communication	44
3.1 Modbus RTU slave communication protocol.....	44
3.2 Addresses word/bit of PL110 for protocol Modbus RTU	45
4 PL110 Ladder programming	50
4.1 Introduction.....	50
4.2 Elements of Ladder programming.....	50

4.2.1	Contacts digital inputs I.....	50
4.2.2	Digital outputs Q.....	50
4.2.3	Bistable relays B.....	51
4.2.4	Timer T.....	51
4.2.5	Counter C.....	52
4.2.6	Mathematical formule FM function.....	53
4.2.7	Assignment function MOV.....	53
4.2.8	Assignment function BLKMOV.....	53
4.2.9	Indexed Assignment Function MOVIND.....	53
4.2.10	Assignment function MOVTXT.....	53
4.2.11	Contacts II immediate digital inputs.....	54
4.2.12	Immediate outputs QI.....	54
4.2.13	IF contact.....	54
4.2.14	Funzioni SBIT e RBIT.....	54
4.2.15	BIT contact.....	54
4.2.16	RANGE function.....	55
4.2.17	Contact NOT.....	56
4.2.18	Contact P and N.....	56
4.2.19	Function SEND and mode Free-port.....	56
4.2.20	Function TunePOS and POS (positioning axis ON/OFF).....	57
4.2.21	Function serial communication COM and EXP.....	59
4.2.22	Functions StartPID , PID , SetOutPID.....	62
4.2.24	Function GENSET.....	63
4.2.25	Function CONV.....	65
4.2.26	Function SetPAR.....	66
4.2.27	Function FormatPAR.....	66
4.2.28	Function PosPAR.....	66
5	PL110-2A user interface terminal.....	68
5.1	Introduction.....	68
5.2	Display and keyboard.....	68
5.3	System pages description.....	70
5.4	User pages description.....	72
5.5	Special pages description.....	76

1 Acquisition and actuation module PL110

1.1 Introduction

Thanks for choosing a Pixsys device. The PL110 is a compact PLC. Distinctive feature is the optional OLED display to visualize/write alphanumeric data. Page structure is pre-programmed but it is possible to choose visualized variables. Pixsys PLprog development tool in Ladder language allows to program via USB port both the operating logic and the visualization. Analogue inputs are available for NTC temperature sensors and V/mA signals. Relay outputs make the PL110 suitable for AC applications. A Real-time clock with back-up battery is available and allows timeframe programming. Connectivity is provided by 2 RS485 ports supporting Modbus-RTU protocol. Additional I/O can be managed with Pixsys expansion modules series MCM260.

Main features	
Operating conditions	Temperature 0-45 °C, Humidity 35..95 rU%
Box	6 DIN rail modules Self-extinguishing polycarbonate / V0
Sealing	Box IP30
Weight	Approx. 250 gr.
Dimensions	90 x 107,6 depth 63 mm

Ordering codes:

PL110 -	<input type="checkbox"/>	<input type="checkbox"/>	
Features	1		8 digital inputs 4 analogue inputs (10 bit resolution) 8 relay outputs 1 analogue 0..10V (8 bit)
	2		8 digital inputs 4 analogue inputs (10 bit resolution) 8 relay outputs 1 analogue 0..10V (8 bit) OLED graphic display 128x64 pixel
Power-supply		A	24V AC/DC

1.2 Front panel and main features

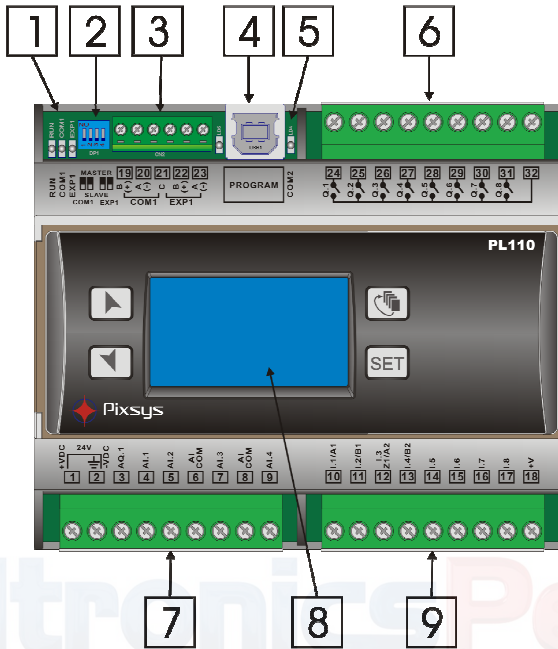

N°	Description
1	<p>Green led RUN:</p> <ul style="list-style-type: none"> ON → PLC is in RUN mode and is executing the instructions programmed by ladder language. Slowly flashing → (0,5 s on / 0,5 s off) boot program and firmware are loaded on PL110, but no ladder application loaded. Fast flashing → (0,2 s on / 0,2 s off) only boot program is loaded on PL110 (no firmware and no ladder application). <p>Yellow led COM1 and EXP1:</p> <ul style="list-style-type: none"> ON → for 50mS during transmission of each frame on one of the available serial ports ON → always during ladder programming or maintenance of PLC (updating main and ladder program)
2	Dip-switch for the selection of master/slave mode for COM1 and EXP1 serial ports.
3	Expansion terminal block for COM1 and EXP1 serial
4	COM2 port USB connector for the connection to the PC, for programming and communication.

N°	Description
5	Yellow led COM2 : <ul style="list-style-type: none"> ON → during output transmission on COM2 port.
6	Relay outputs terminal block
7	Power-supply terminal block, analogue inputs/output
8	Terminal with OLED display and keys (only on PL110-2A)
9	Digital inputs terminal block

1.3 Main hardware features

Hardware		
Power-supply	+VDC -VDC	24V AC/DC 6VA
Analogue inputs	AI.1	Current 0-20mA / 4-20mA (10 bit resolution)
	AI.2	Tension 0-10V (10 bit resolution)
	AI.3	Input NTC-10K = $\beta 3435$ Potentiometer 10 K Ω (10 bit resolution)
	AI.4	Input NTC-10K = $\beta 3435$ Potentiometer 10 K Ω (10 bit resolution)
Encoder inputs ¹	I.1/A1 I.2/B1 I.3/Z1	1st input for bidirectional encoder
	I.3/A2 I.4/B2	2nd input for bidirectional encoder
Digital inputs	I.1÷I.8	Inputs PNP V _{LH} = 15,0V (threshold "0" → "1") V _{HL} = 10,5V (threshold "1" → "0")

¹ First encoder input uses hardware inputs I1 and I2, eventually also I3 for the management of zero signal (in this case it is not possible to use the second encoder). Second encoder input uses hardware inputs I3 and I4. If encoder inputs are used, the relevant digital inputs are not available. Max. frequency for encoders is 25 KHz if not used contemporarily, 15 KHz if both inputs are used contemporarily. The PL110 notices positive and negative signals of the A signal, so it redouble the number of counts/turns.

Hardware		
Relay outputs	Q.1÷Q.8	2A 250Vac/30Vdc resistive load (p.f.=1) 1A 250Vac/30Vdc inductive load (p.f.=0.40) 6A max. total current Q.1÷Q.8
Analogue output	AQ.1	0-10V (8 bit resolution)
Communication port ²	COM1	RS485 available on terminal block
	EXP1	RS485 available on terminal block
	COM2	USB (VCP virtual comm port)



² Serial ports are isolated from power-supply, inputs and outputs. COM1 and EXP1 are not isolated between each other.

1.4 Size and installation

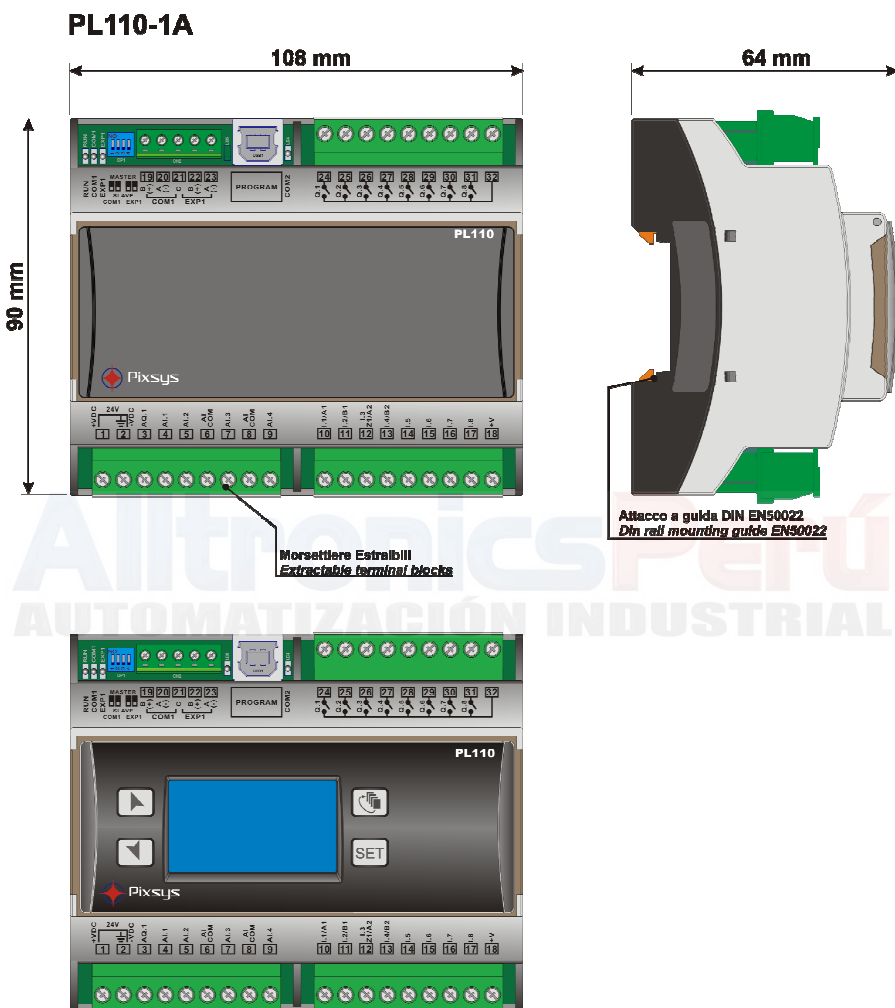

1.5 Electrical wirings

1.5.1 Connectors and terminal blocks

N°	Name	Description		
1	+VDC	Power-supply 24V AC/DC 6VA. To improve noise immunity, the use of a dedicated supply or transformer is recommended.		
2	-VDC $\underline{\underline{=}}$	N.B.: If more devices are connected in AC using the same transformer, it is necessary to comply with polarity of the power connection between the various devices.		
3	AQ.1	Analogue output AQ.1 positive signal (0÷10 VDC)		
4	AI.1	Analogue input AI.1 positive signal		
5	AI.2	Analogue input AI.2 positive signal		
6	AI-COM	Common negative signal for analogue inputs AI.1 e AI.2		
7	AI.3	Analogue input AI.3 positive signal		
8	AI-COM	Common negative signal for analogue inputs AI.3 e AI.4		
9	AI.4	Analogue input AI.4 positive signal		
10	I.1 / A1	Digital input	Input for bidirectional encoder no.1 Signal A.	Inputs PNP V _{LH} = 15,0V threshold "0"→"1" V _{HL} = 10,5V threshold "1"→"0" To activate digital inputs, switch the signal +V (pin 18) to the input pin.
11	I.2 / B1	Digital input	Input for bidirectional encoder no.1 Signal B.	
12	I.3 Z1 / A2	Digital input	Input for bidirectional encoder no. 1 signal Zero, or input for bidirectional encoder no. 2 Signal A.	
13	I.4 / B2	Digital input	Input for bidirectional encoder no. 2 Signal B.	
14	I.5	Digital input		
15	I.6	Digital input		
16	I.7	Digital input		
17	I.8	Digital input		

N°	Name	Description	
18	+V	Common positive signal for digital inputs. Connect this signal to one of the digital inputs I1÷I18, to activate inputs. Tension available on these pins can supply sensors to be connected to the analogue inputs (max 20mA). (N.B.: on these pins the available supply is Vcc, not stabilized!).	
19	B	Signal RS485+	COM1 serial
20	A	Signal RS485-	COM1 serial
21	C	Signal RS REF	COM1 and EXP1 interface
22	B	Signal RS485+	EXP1 interface
23	A	Signal RS485-	EXP1 interface
	PROGRAM	USB	COM2 VCP of programming
24	Q.1	Relay output	Contacts features: 2A 250Vac/30Vdc resistive load (p.f.=1) 1A 250Vac/30Vdc inductive load (p.f.=0.40)
25	Q.2	Relay output	
26	Q.3	Relay output	
27	Q.4	Relay output	
28	Q.5	Relay output	
29	Q.6	Relay output	
30	Q.7	Relay output	
31	Q.8	Relay output	
32		Common relay outputs	6A max. total current Q.1÷Q.8

1.5.2 Connection of sensors to analogue inputs

Below some examples of connection for common sensors to the analogue inputs of the PL110.

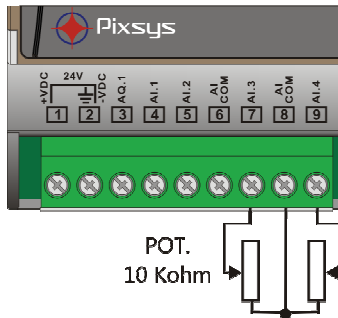
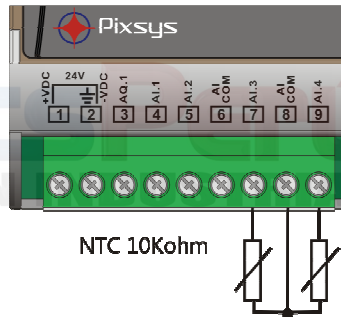
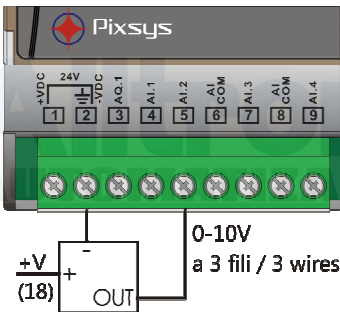
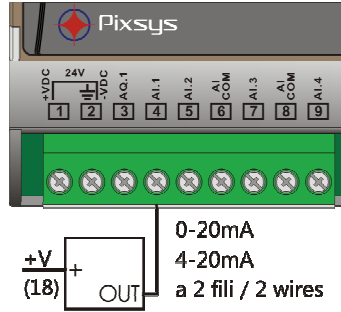
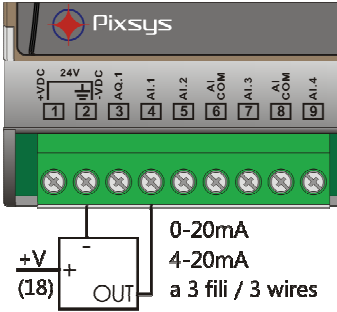

1.5.3 Connection of a bidirectional encoder

Below an example of connection for a typical bidirectional encoder (phase A,B and Z optional) which can be connected to the PL110 inputs. The device allows to connect up to two encoders. The Z signal management is available if only one encoder is used.

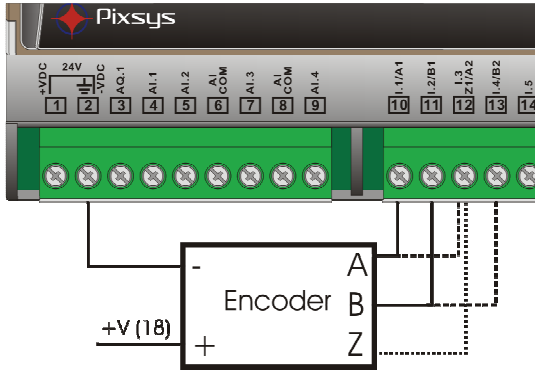

1.5.4 Connect PL110 to RS485

Below an example of connection for more modules PL110 to RS485 line for the communication with a master device through COM1 in slave mode.

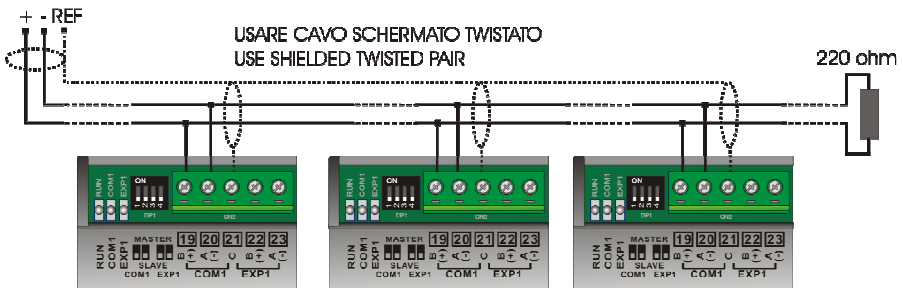

1.6 Setting dip-switch and rotary-switch

The PL110 is provided with some dip-switches and a rotary-switch which allow the user to configure COM1 and EXP1 serials as master or slave, and to select the device address.

N.B. All hardware configuration procedures must be done with PL110 switched off.

1.6.1 Setting dip-switches to select COM1 interface

The dip-switches 1 and 2 select the serial interface COM1 for the use in master or slave mode. If master mode is selected, through the dip-switches, it is possible to connect the polarizers (470 ohm) and the line termination resistors (330 ohm) to RS485. If slave mode is selected, RS485 is devoid of any polarization or termination resistance.

- COM1 serial in slave mode (dip 1 and 2 OFF)

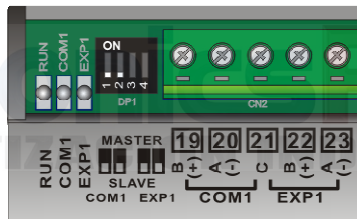

- COM1 serial in master mode (dip 1 and 2 ON)

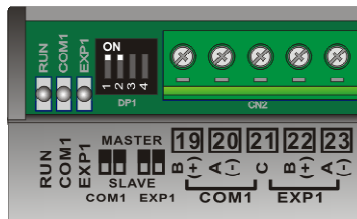

1.6.2 Setting dip-switches to select master / slave EXP1

The dip-switches 3 and 4 select the serial interface EXP1 for the use in master or slave mode. If master mode is selected, through the dip-switches, it is possible to connect the polarizers (470 ohm) and the line termination resistors (330 ohm) to RS485. If slave mode is selected, the line RS485 is devoid of any polarization or termination resistance.

- EXP1 serial in slave mode (dip 3 and 4 OFF)

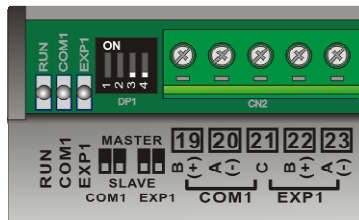

- EXP1 serial in master mode (dip 3 and 4 ON)

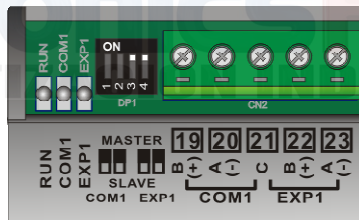

1.6.3 Setting PL110-1A protocol address

The PL110-1A is provided with an internal rotary-switch (accessible by lifting the box cover) to select the address for serial communication with a master device. The rotary-switch allows 16 combinations, to connect more than 16 devices on the same line it is necessary to modify the parameter which indicates the offset address. This module address is given by:

$$\text{MODULE ADDRESS} = \text{ADDRESS OFFSET (SMW4)} + \text{ROTARY-SWITCH VALUE}$$

The address offset, value kept on the PL110 memory (default "0"), can be modified writing on the word SMW4.

The correspondence between the position of the rotary switch and the module address is summarized in the following table:

ROTARY POSITION	ROTARY VALUE	MODULE ADDRESS
0	0	SMW4 + 0
1	1	SMW4 + 1
2	2	SMW4 + 2
3	3	SMW4 + 3
4	4	SMW4 + 4
5	5	SMW4 + 5
6	6	SMW4 + 6
7	7	SMW4 + 7
8	8	SMW4 + 8
9	9	SMW4 + 9
A	10	SMW4 + 10
B	11	SMW4 + 11
C	12	SMW4 + 12
D	13	SMW4 + 13
E	14	SMW4 + 14
F	15	SMW4 + 15

1.6.4 Setting PL110-2A protocol address

The setting of the PL110-2A address for serial communication with a master device is done through the special marker SMW4. This module address is given by:

MODULE ADDRESS = ADDRESS OFFSET (SMW4)

The address offset, value kept on the PL110 memory (default "1"), can be modified writing on word SMW4.

This value can be changed through the specific system page entering the password "1357".

2 PL110 memory

2.1 PL110 memory areas

The PL110 module provides the user with memory areas where it is possible to read or write program data. Memory areas can be entered by instruction with access by single bit (B), by word (W) or double word (D).

CODE	AREA	ACCESS
V	Variables V area	B, W, D
SM	Special Marker area	B, W, D
I	Digital inputs area	B, W
AI	Analogue inputs area	B, W
Q	Digital outputs area	B, W
M	Marker area	B, W
AQ	Analogue outputs area	B, W
T	Timer area	B, W
PT	Preset Timer area	B, W
C	Counters area	B, W
PV	Preset counters area	B, W
EEP	EEPROM area	W
MMC	EEPROM_MEMORY area	W
COM1_TX	COM1_TX area	W
COM1_RX	COM1_RX area	W
EXP1_TX	EXP1_TX area	W
EXP1_RX	EXP1_RX area	W
COM2_TX	COM2_TX area	W
COM2_RX	COM2_RX area	W
DISPLAY	Display digits area	W

2.1.1 Variables V memory area

The memory area “Variables V” is the memory which is used by the program to store data of operations. It is composed by 350 locations, type word (175 double words). This area may be edited by operations on bit, word or double word. The number of double word still refers to the words structure, therefore a single double word uses 2 single word addresses.

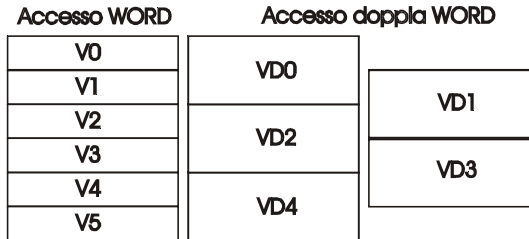

The values are stored also in case of power failure thanks to a rechargeable back-up battery. After charging, the battery stores data for approx. 6 months

2.1.2 Memory area “special marker SM”

This area is the memory which contains all data used by the ladder program to interact with the hardware resources of PL110. Some of this data is initialized when starting the PLC with the default values described in the table below. This area contains all data related to analogue inputs/ouputs, counts and set values of encoders, and also some bits controlled by the PLC for the ladder application as well as the settings for the communication serial ports.

The table below includes the content of each single location of the area “Special markers”, giving the address for Modbus protocol and the type of operation allowed for each location (R=reading, W=writing, R/W=reading/writing).

SM n°	Mod. word	Description / meaning	
SM0	1000	Status bit	
		Bit 0	RUN/STOP bit (1=run). At starting this bit is always forced to ON, obtaining the RUN mode of PLC. In STOP mode, the relay outputs of PLC are disabled. R/W
		Bit 1	This bit is always ON for first scanning cycle of main program. Eg. It is used to execute initialization subprogram. R
		Bit 2	This bit makes available a clock impulse of 60 seconds (ON for 30 seconds, OFF for 30 seconds). R
		Bit 3	This bit makes available a clock impulse of 1 second (ON for 0,5 second, OFF for 0,5 second) R
		Bit 4	This bit is a clock of scanning cycle, which is active ON for one cycle and disabled OFF for following cycle. It may be used as counting input for scanning cycle. R
		Bit 5	Bit TEST. Setting this bit as ON, the reading of digital inputs is disabled. Status of inputs is read on word SM37. Setting this word, it is possible to execute debug/test of the program simulating input starting. R/W
		Bit 6	This bit is ON during the transmission of data to serial port COM1. It is automatically set to OFF at the end of transmission. R
		Bit 7	This bit is ON during the transmission of data to serial port EXP1. It is automatically set to OFF at the end of transmission. R
		Bit 8	This bit is ON during the transmission of data to serial port COM2. It is automatically set to OFF at the end of transmission. R
		Bit 9	If set to ON this bit enables mode "modem" for serial port COM1. This means that Timeout between one character and the other character in receiving mode is automatically set to 40mS. R/W

Bit 10	If set to ON this bit enables mode “modem” for serial port EXP1. This means that Timeout between one character and the other character in receiving mode is automatically set to 40mS.	R/W
Bit 11	If set to ON this bit enables mode “modem” for serial port COM2. This means that Timeout between one character and the other character in receiving mode is automatically set to 40mS.	R/W
Bit 12	If set to 1, this bit disables internal clock reading/writing, making faster program execution.	R/W
Bit 13	If set to 1, this bit disables counters C[1..16] and enables timers T[49..64], normally disabled.	R/W

SM1	1001	Diagnostic Bit (faults/anomalies)	
	Bit 0	This bit is ON if the retaining data of the area "special marker" are lost.	R/W
	Bit 1	This bit is ON if the retaining data of the "marker" area are lost.	R/W
	Bit 2	This bit is ON if the retaining data of EEPROM area are lost.	R/W
	Bit 3	This bit is ON if calibration data are lost.	R/W
	Bit 4	This bit is ON if the CPU has been reset or if there is a watch-dog intervention.	R/W
	Bit 5	This bit is ON if there is stack overflow on the ram reserved area.	R/W
	Bit 6	This bit is ON if an error has occurred during the calibration process.	R/W
	Bit 7	This bit is ON if there is an error/fault of serial EEPROM.	R/W
	Bit 8	This bit is ON if there is an error/fault of serial clock.	R/W
	Bit 9	Not used.	R/W
	Bit 10	This bit is ON if there is a stack overflow of timed interrupts.	R/W
	Bit 12	This bit is ON if the analogue AI1 input is out of range.	R
	Bit 13	This bit is ON if the analogue AI2 input is out of range.	R
	Bit 14	This bit is ON if the analogue AI3 input is out of range.	R
	Bit 15	This bit is ON if the analogue AI4 input is out of range.	R

SM2	1002	Bit for management of bidirectional encoders / step motor	
	Bit 0	Loading of counter for bidirectional encoder 1. Setting this bit to "1", at the end of scanning cycle, the counter of encoder1 (32 bit) is loaded with the value of special marker n°24 (high part) and of special marker n°25 (low part). The bit is automatically set to OFF at the end of operation.	R/W
	Bit 1	Loading of counter for bidirectional encoder 2. Setting this bit to "1", at the end of scanning cycle, the counter of encoder 2 (32 bit) is loaded with the value of special marker n°26 (high part) and of special marker n°27 (low part). The bit is automatically set to OFF at the end of operation.	R/W
	Bit 2	Loading counter of bidirectional encoder 1 with zero impulse. Setting this bit to "1", at the next zero impulse of encoder 1 (connected to input I3), the counter of encoder1 (32 bit) is loaded with the value of special marker n°24 (high part) and of special marker n°25 (low part). The bit is automatically set to OFF at the end of operation.	R/W
	Bit 3	Not used.	-
	Bit 4	This bit, if set to "1" on "INITIALIZATION CODE" of program ladder, enables the management of a step motor. N.B.: If step motor is enabled, timed interrupt no. 1 is no longer active.	R/W

	Bit 5	This bit, if set to "1" (only if SM2.4 = 1), enables output AQ1 to manage step motor.	R/W
	Bit 6	This bit, if set to "1" (only if SM2.4 = 1 and SM2.5 = 1), creates on output AQ1 a series of impulses 0-5V and frequency equal to the one selected on SM16 (step motor final frequency). The final frequency is reached after an acceleration ramp whose duration (in ms) is specified by SM18.	R/W
SM4	1004	PL110 protocol address offset (default 0)	
		This word contains the PL110 protocol address offset. Its value is added to the one obtained by the address selection rotary-switch (see paragraph 1.6.3). At start it is fixed to 0.	R/W
SM5	1005	Rotary-switch status	
		This word indicates the value correspondent to the position of the selection rotary-switch.	R
SM6	1006	Cycle time	
		This word gives the time of the program last scanning cycle (resolution 100 μ S).	R
SM7	1007	Min. cycle time	
		This word gives the min. time of the program last scanning cycle (resolution 100 μ S).	R
SM8	1008	Max. cycle time	
		This word gives the max. time of the program last scanning cycle (resolution 100 μ S).	R

SM9	1009	Internal clock seconds (0..59)	
SM10	1010	Internal clock minutes (0..59)	
SM11	1011	Internal clock hours (0..23)	
SM12	1012	Internal clock day (1..31)	
SM13	1013	Internal clock month (1..12)	
SM14	1014	Internal clock year (0..99)	
SM15	1015	Internal clock day of the week (0..6) (0→ Sunday, 1→ Monday, ... 6→ Saturday)	
		These words contain the date and time of the internal clock. Writing on each of these words updates the internal clock. An internal battery allows the clock to function during a power failure.	R/W
SM16	1016	Interval of timed interrupt no. 1 (default 100 ms)	
SM17	1017	Interval of timed interrupt no. 2 (default 100 ms)	
		These words define the interval for timed interrupts. Value of interval may be set between 1 and 100 ms (esempio: SM16=1 → 1 ms SM16=100 → 100 ms). For SM16 and SM17 values not included between 1 and 100, the default setting of relevant interrupt is 100 ms. At starting the values are fixed as 100 → 100 ms. On the interrupts ladder programs it is not allowed to use functions which access EEPROM and MMC areas.	R/W
SM20	1020	Counts of bidirectional counter encoder 1 (high area)	
SM21	1021	Counts of bidirectional counter encoder 1 (low area)	
SM22	1022	Counts of bidirectional counter encoder 2 (high area)	
SM23	1023	Counts of bidirectional counter encoder 2 (low area)	
		These two pairs of words contain the value of bidirectional counters for encoders 1 and 2. Counting is stored also if there is a power failure and it is automatically updated at each program scanning.	R
SM24	1024	Loading value for counter of encoder 1 (high area)	
SM25	1025	Loading value for counter of encoder 1 (low area)	
		These words contain the value (in counts) which is loaded on the counter of encoder 1 when the loading bit SM2.0 is set to "1".	R/W
SM26	1026	Loading value for counter of encoder 2 (high area)	
SM27	1027	Loading value for counter of encoder 2 (low area)	
		These words contain the value (in counts) which is loaded on the counter of encoder 2 when the loading bit SM2.1 is set to "1".	R/W

SM28	1028	Counts per second of encoder 1	
SM29	1029	Counts per second of encoder 2	
		These words contain the number of counts completed by the encoders during the last second. These words are automatically updated at each second.	R
SM30	1030	Counts per tenth of second for encoder 1	
SM31	1031	Counts per tenth of second for encoder 2	
		These words contain the number of counts completed by the encoders during the last 100 ms. These words are automatically updated at each 100 ms.	R
SM37	1037	Status of digital inputs I1÷I8 for test procedure	
		This word defines the status for digital inputs during test procedure (SM0.5=1). Each bit of this word corresponds to the status of a digital input, starting from the bit less significant (SM37.0→I1, SM37.7→I8). This word is zeroed automatically at each starting.	R/W
SM38	1038	Digital inputs filter (default 10 ms)	
		It is possible to filter the signals of digital inputs selecting a delay time. If the input status changes, the new status will be accepted only if it is stored by the input for the selected time. Data will be accepted only when the filter will have cancelled noises and fixed inputs lines on stable values. PL110 supports filters with delay time between 0 and 50 ms.	R/W

SM39	1039	Analogue inputs filter (default 5 means)	
		A filter may be applied to the signals of analogue inputs, selecting the number of values to consider in the average for the rating of final input value/ to exclude software filter (means) for each input/ to exclude control function which automatically rejects wrong conversions.	R/W
	Bit 0+3	These bits select the number of values to consider in the average to calculate input value. 1..5 → number of conversions considered in the average.	R/W
	Bit 4	Input AI1 software filter exclusion. 0 → filter enabled 1 → filter excluded	R/W
	Bit 5	Input AI2 software filter exclusion. 0 → filter enabled 1 → filter excluded	R/W
	Bit 6	Input AI3 software filter exclusion. 0 → filter enabled 1 → filter excluded	R/W
	Bit 7	Input AI4 software filter exclusion. 0 → filter enabled 1 → filter excluded	R/W
	Bit 8	Not used.	R/W
	Bit 9	Not used.	R/W
	Bit 10	AI1 false conversions discard. 0 → discard enabled 1 → discard disabled	R/W
	Bit 11	AI2 false conversions discard. 0 → discard enabled 1 → discard disabled	R/W
	Bit 12	AI3 false conversions discard. 0 → discard enabled 1 → discard disabled	R/W
	Bit 13	AI4 false conversions discard. 0 → discard enabled 1 → discard disabled	R/W
	Bit 14	Not used.	R/W
	Bit 15	Not used.	R/W

SM40	1040	Analogue input AI1 configuration	
SM41	1041	Analogue input AI2 configuration	
SM42	1042	Analogue input AI3 configuration	
SM43	1043	Analogue input AI4 configuration	
		These special marker words define the type of sensor connected to analogue inputs AI1...AI4. 0 → Input disabled 1 → Linear input 0÷10V ³ 2 → Linear input 0÷20mA ⁴ 3 → Linear input 4÷20mA ⁵ 4 → Input NTC-10K $\beta=3435$ ⁶ 5 → Potentiometer 10 K Ω ⁷	R/W
SM44	1044	Min. value for Analogue input AI1 linear	
SM45	1045	Min. value for Analogue input AI2 linear	
SM46	1046	Min. value for Analogue input AI3 linear	
SM47	1047	Min. value for Analogue input AI4 linear	
SM48	1048	Max. value for Analogue input AI1 linear	
SM49	1049	Max. value for Analogue input AI2 linear	
SM50	1050	Max. value for Analogue input AI3 linear	
SM51	1051	Max. value for Analogue input AI4 linear	
		Select min. and max. numeric limits for the analogue conversion of inputs AI configured as V/I/ Ω (current, tension and potentiometer). These words are modified using the instruction RANGE (AIx,Min,Max). Default settings are 0 for min. value and 1000 for max. value.	R/W

³ Only for AI.2

⁴ Only for AI.1

⁵ Only for AI.1

⁶ Only for AI.3 and AI.4

⁷ Only for AI.3 and AI.4

SM52	1052	Offset calibration Analogue input AI1	
SM53	1053	Offset calibration Analogue input AI2	
SM54	1054	Offset calibration Analogue input AI3	
SM55	1055	Offset calibration Analogue input AI4	
SM56	1056	Gain calibration Analogue input AI1	
SM57	1057	Gain calibration Analogue input AI2	
SM58	1058	Gain calibration Analogue input AI3	
SM59	1059	Gain calibration Analogue input AI4	
		These words define the calibration of conversion for AI1..AI4. They are used to correct possible errors of reading. The formule is as follows: Value AIx = Value AIx + (Value AIx * Gain calibration AIx) / 1000 Offset calibration AIx. At starting all calibration values are set to 0.	R/W
SM60	1060	Min. value for analogue output AQ1	
		This word defines the value of the software analogue output AQx which corresponds to 0V on the hardware output. This word is modified using the instruction RANGE(AQx,Min,Max). At starting it is selected to 0.	R/W
SM61	1061	Max. value for analogue output AQ1	
		This word defines the value of the software analogue output AQx which corresponds to 10V on the hardware output. This word is modified using the instruction RANGE(AQx, Min, Max). At starting it is selected to 100.	R/W

SM70	1070	Serial COM1 status														
SM80	1080	Serial EXP1 status														
SM90	1090	Serial COM2 status														
		<p>These words define the status of communication serials COM1, EXP1 and COM2. Each bit of each word signals a condition of missing communication (off-line) or an error for each transmitted/received data by instructions COM_1÷16 or EXP_1÷16 (ex. SM100.0=1 shows the error on COM_1(...) instruction).</p> <p>If serial is selected on slave protocol, the error condition is signaled setting to "1" all bits of correspondent word whenever no correct packet with slave address same as the device is not received within the time fixed on SM105, SM115 and SM125.</p>		R												
SM71	1071	COM1 baudrate (default 19200 baud)														
SM81	1081	EXP1 baudrate (default 19200 baud)														
SM91	1091	COM2 baudrate (default 57600 baud)														
		<p>Value selected into this word defines the serial port communication speed⁸.</p> <table style="width: 100%; border: none;"> <tr> <td style="width: 50%;">0 → 110 baud</td> <td style="width: 50%;">6 → 4800 baud</td> </tr> <tr> <td>1 → 150 baud</td> <td>7 → 9600 baud</td> </tr> <tr> <td>2 → 300 baud</td> <td>8 → 19200 baud</td> </tr> <tr> <td>3 → 600 baud</td> <td>9 → 28800 baud</td> </tr> <tr> <td>4 → 1200 baud</td> <td>10 → 38400 baud</td> </tr> <tr> <td>5 → 2400 baud</td> <td>11 → 57600 baud</td> </tr> </table>		0 → 110 baud	6 → 4800 baud	1 → 150 baud	7 → 9600 baud	2 → 300 baud	8 → 19200 baud	3 → 600 baud	9 → 28800 baud	4 → 1200 baud	10 → 38400 baud	5 → 2400 baud	11 → 57600 baud	R/W
0 → 110 baud	6 → 4800 baud															
1 → 150 baud	7 → 9600 baud															
2 → 300 baud	8 → 19200 baud															
3 → 600 baud	9 → 28800 baud															
4 → 1200 baud	10 → 38400 baud															
5 → 2400 baud	11 → 57600 baud															

⁸ To enable modifications it is necessary to set this word within initialization function. If no modification has been completed or if it has been done in other sections of the program, baud-rate will be kept as default at starting.

SM72	1072	Serial COM1 format	
SM82	1082	Serial EXP1 format	
SM92	1092	Serial COM2⁹ format	
		Value selected into this word defines the serial port communication data ¹⁰ . 0 → 8,N,1 (default) 6 → 8,N,2 1 → 8,O,1 7 → 8,O,2 2 → 8,E,1 8 → 8,E,2 3 → 7,N,1 9 → 7,N,2 4 → 7,O,1 10 → 7,O,2 5 → 7,E,1 11 → 7,E,2	R/W
SM73	1073	Delay answer/wait incoming data COM1 (def.20ms)	
SM83	1083	Delay answer/wait incoming data EXP1 (def. 20ms)	
SM93	1093	Delay answer/wait incoming data COM2 (def. 0ms)	
		With slave protocol this word defines min. delay between end of data receiving from master device and the start of answer transmission form PL110 (max. 100ms). With master protocol this word define max. waiting between start of query transmission from PL110 and full receiving of answer from slave device. Value is expressed in ms.	R/W
SM74	1074	Delay new master transmission COM1 (default 5 ms)	
SM84	1084	Delay new master transmission EXP1 (default 5 ms)	
SM94	1094	Delay new master transmission COM2 (default 5 ms)	
		With master protocol this word defines min. waiting between end of data receiving (from slave to master), and start of transmission for a new query from master to slave. With slave protocol this value is not used. Value is expressed in ms, range 0-100 ms.	R/W

⁹ Format may not be modified (8,N,1).

¹⁰ To enable modifications it is necessary to set this word within initialization

function. If no modification has been completed or if it has been done in other sections of the program, baud-rate will be kept as default at starting.

SM75	1075	Number of errors for signal on status COM1 (def. 10)	
SM85	1085	Number of errors for signal on status EXP1 (def. 10)	
SM95	1095	Number of errors for signal on status COM2 (def. 10)	
		Value entered for this word defines: If master protocol - the number of consecutive communication errors after which the anomaly is notified in the relevant bit of "serial status". If slave protocol - the time in seconds after that the anomaly is notified keeping to "1" all bit of the word "serial status".	R/W
SM76	1076	Number of timeouts on COM1	
SM86	1086	Number of timeouts on EXP1	
SM96	1096	Number of timeouts on COM2	
		These words are counters (reset at starting) which are incremented at each timeout noticed by the function for the managing of each serial port protocol.	R/W
SM77	1077	Number of errors on COM1	
SM87	1087	Number of errors on EXP1	
SM97	1097	Number of errors on COM2	
		These words are counters (reset at starting) which are incremented at each error (Ex. wrong checksum, wrong number of received data) noticed by the function for the managing of each serial port protocol.	R/W

SM78	1078	COM1 configuration in free-port mode													
SM88	1088	EXP1 configuration in free-port mode													
SM98	1098	COM2 configuration in free-port mode													
		These words enable functioning of serial port in freeport mode, selecting also functioning parameters. Enabling this mode, communication protocol which uses the serial is disabled and so it is possible to access directly the transmission/reception of data on port. These parameters, at switch on, are selected to 0 (free-port mode disabled).	R/W												
	Bit 0÷3	<p>These bit select communication speed for the serial port in free-port mode, according to this values:</p> <table border="0"> <tr> <td>0 → 110 baud</td> <td>6 → 4800 baud</td> </tr> <tr> <td>1 → 150 baud</td> <td>7 → 9600 baud</td> </tr> <tr> <td>2 → 300 baud</td> <td>8 → 19200 baud</td> </tr> <tr> <td>3 → 600 baud</td> <td>9 → 28800 baud</td> </tr> <tr> <td>4 → 1200 baud</td> <td>10 → 38400 baud</td> </tr> <tr> <td>5 → 2400 baud</td> <td>11 → 57600 baud</td> </tr> </table>	0 → 110 baud	6 → 4800 baud	1 → 150 baud	7 → 9600 baud	2 → 300 baud	8 → 19200 baud	3 → 600 baud	9 → 28800 baud	4 → 1200 baud	10 → 38400 baud	5 → 2400 baud	11 → 57600 baud	R/W
0 → 110 baud	6 → 4800 baud														
1 → 150 baud	7 → 9600 baud														
2 → 300 baud	8 → 19200 baud														
3 → 600 baud	9 → 28800 baud														
4 → 1200 baud	10 → 38400 baud														
5 → 2400 baud	11 → 57600 baud														
	Bit 4÷7	<p>These bits select the format for the serial port communication data in free-port mode:</p> <table border="0"> <tr> <td>0 → 8,N,1</td> <td>6 → 8,N,2</td> </tr> <tr> <td>1 → 8,O,1</td> <td>7 → 8,O,2</td> </tr> <tr> <td>2 → 8,E,1</td> <td>8 → 8,E,2</td> </tr> <tr> <td>3 → 7,N,1</td> <td>9 → 7,N,2</td> </tr> <tr> <td>4 → 7,O,1</td> <td>10 → 7,O,2</td> </tr> <tr> <td>5 → 7,E,1</td> <td>11 → 7,E,2</td> </tr> </table>	0 → 8,N,1	6 → 8,N,2	1 → 8,O,1	7 → 8,O,2	2 → 8,E,1	8 → 8,E,2	3 → 7,N,1	9 → 7,N,2	4 → 7,O,1	10 → 7,O,2	5 → 7,E,1	11 → 7,E,2	R/W
0 → 8,N,1	6 → 8,N,2														
1 → 8,O,1	7 → 8,O,2														
2 → 8,E,1	8 → 8,E,2														
3 → 7,N,1	9 → 7,N,2														
4 → 7,O,1	10 → 7,O,2														
5 → 7,E,1	11 → 7,E,2														
	Bit 8	This bit selected to "1" enables mode free-port, if selected to "0" it keeps serial to normal mode where it is managed directly by the selected protocol into the programming phase.	R/W												

SM79	1079	Number of characters present in the reception buffer of serial COM1	
SM89	1089	Number of characters present in the reception buffer of serial EXP1	
SM99	1099	Number of characters present in the reception buffer of serial COM2	
		These words contains for each serial, the number of valid characters present into reception buffer. The use of these words is significant on free-port mode to control number of received characters. Any writing on these words, selects value corresponding to zero, emptying reception buffer.	R/W
SM100	1100	Display brightness in standby (default 0=OFF)	
		This word defines the % value of display brightness in standby. If enabled, standby activates after the time in minutes indicated on SMW101 elapsed from the last key pressure. To avoid disturbing the environment with light and to improve the display lifecycle.	R/W
SM101	1101	Display delay in standby (default 2)	
		This word defines the time in minutes elapsed from the last key pressure, after which the display goes in standby reducing the brightness. When display is in standby, press one of the keys to restore max. brightness. Setting this word to 0, standby mode is deactivated.	R/W
SM102	1102	Enabling system pages (default 31= all enabled)	
		Acting on bits of this word it is possible to enable or disable the system pages visualization. Each bit is related to a system page, if the bit is "1" the page is enabled, if the bit is "0" the page is disabled and not visualized.	R/W
		Bit 0 Enables page 1, digital I/O status	R/W
		Bit 1 Enables page 2, analogue inputs status	R/W
		Bit 2 Enables page 3, system info	R/W
		Bit 3 Enables page 4, date & hour	R/W
		Bit 4 Enables page 5, setup display	R/W

SM103	1103	Enabling user pages (default 0= all disabled)	
		Acting on bits of this word it is possible to enable or disable the system pages visualization. Each bit is related to a system page, if the bit is "1" the page is enabled, if the bit is "0" the page is disabled and not visualized.	R/W
		Bit 0	Enables user page n° 17
		Bit 1	Enables user page n° 18
		Bit 2	Enables user page n° 19
		Bit 3	Enables user page n° 20
		Bit 4	Enables user page n° 21
		Bit 5	Enables user page n° 22
		Bit 6	Enables user page n° 23
		Bit 7	Enables user page n° 24
		Bit 8	Enables user page n° 25
		Bit 9	Enables user page n° 26
		Bit 10	Enables user page n° 27
		Bit 11	Enables user page n° 28
		Bit 12	Enables user page n° 29
		Bit 13	Enables user page n° 30
		Bit 14	Enables user page n° 31
		Bit 15	Enables user page n° 32
SM104	1104	Starting page number (default 1)	
		Defines the first page to be visualized at starting after the splash-screen with Pixsys logo and PLC model. To modify default settings, select this word SM on the initialization code.	R/W
SM105	1105	Number of visualized page	
		Shows the number of the page actually visualized on display. This word is useful to configure the user pages, it is possible to define some ladder code blocks in correspondence of the values for this word between 17 and 32 to select the user pages structure.	R
SM106	1106	Page number to visualize (default 0)	
		In this word it is possible to write the number of the page to be visualized on display. If the page exists and is enabled it will be visualized; if the value is not correct the visualization will remain at the current page. Once activated the requested page, the word will automatically be forced to 0.	R/W

SM107	1107	Number area of the last modified variable (default 0)	
<p>This word indicates (for a single scanning cycle) the index corresponding to the last memory area saved by the terminal. Here below the areas index:</p>			R
Area word V → 1			
Area word SM → 2			
Area word AI → 3			
Area word TR → 4			
Area word AQ → 5			
Area word I → 6			
Area word Q → 7			
Area word T → 8			
Area word PT → 9			
Area word C → 10			
Area word PV → 11			
Area double V → 12			
Area double SM → 13			
Area word M → 14			
Area word EEPROM → 15			
Area word MMC → 16			
Area byte TX EXP1 → 19			
Area byte RX EXP1 → 20			
Area byte TX COM2 → 21			
Area byte RX COM2 → 22			
Area byte DISP → 23			
SM108	1108	Number area of the last modified variable (default 0)	
<p>This word indicates (for a single scanning cycle) the number of the last memory area saved by the terminal.</p>			R
<p>If the variable VW30 is modified by the terminal, only for the scanning cycle following the modification, special markers will be SM107 = 1 and SM108 = 30. During the next cycle the two areas will automatically go back to 0.</p>			

SM109	1109	Password (default 0)	
		This word indicates the value of the entered password. To allow modification of the input fields protected by password it is necessary to enter "1234", while to set the parameter "SLAVE ADDRESS" by terminal it is necessary to enter "1357". The password can be entered manually, by terminal or by ladder instructions	R/W
SM110	1110	Pressed key (default 0)	
		This word indicates the combination of the pressed keys. The bit to "1" indicates that the corresponding key is pressed.	R
		Bit 0 SWAP key	
		Bit 1 UP key	
		Bit 2 DOWN key	
		Bit 3 SET key	
SM118	1118	Parameter 1 status (default 0)	
SM135	1135	Parameter 2 status (default 0)	
SM152	1152	Parameter 3 status (default 0)	
SM169	1169	Parameter 4 status (default 0)	
		These words, and the followings ones contain values selected by SetPar, FormatPAR and PosPAR ladder functions to set numeric fields to be visualized on user pages. These words, for each of the 4 parameter fields, can take this values: 0 → Disabled 1 → Visualized 2 → Modification	R/W

SM119	1119	Parameter 1 area number (default 0)	
SM136	1136	Parameter 2 area number (default 0)	
SM153	1153	Parameter 3 area number (default 0)	
SM170	1170	Parameter 4 area number (default 0)	
		These words indicate the memory area to which refer the parameter fields visualized on display. Refer to SM107 for the complete list of variable areas.	R/W
SM120	1120	Parameter 1 number (high part) (default 0)	
SM121	1121	Parameter 1 number (low part) (default 0)	
SM137	1137	Parameter 2 number (high part) (default 0)	
SM138	1138	Parameter 2 number (low part) (default 0)	
SM154	1154	Parameter 3 number (high part) (default 0)	
SM155	1155	Parameter 3 number (low part) (default 0)	
SM171	1171	Parameter 4 number (high part) (default 0)	
SM172	1172	Parameter 4 number (low part) (default 0)	
		These double words indicate the number of the memory variable to which refer the parameter fields visualized on display.	R/W
SM122	1122	Parameter 1 min. area number (default 0)	
SM139	1139	Parameter 2 min. area number (default 0)	
SM156	1156	Parameter 3 min. area number (default 0)	
SM173	1173	Parameter 4 min. area number (default 0)	
		These words indicate the memory area to which refer the min. limits of the parameter fields visualized on display. Refer to SM107 for the complete list of variable areas.	R/W
SM123	1123	Parameter 1 min. number (high part) (default 0)	
SM124	1124	Parameter 1 min. number (low part) (default 0)	
SM140	1140	Parameter 2 min. number (high part) (default 0)	
SM141	1141	Parameter 2 min. number (low part) (default 0)	
SM157	1157	Parameter 3 min. number (high part) (default 0)	
SM158	1158	Parameter 3 min. number (low part) (default 0)	
SM174	1174	Parameter 4 min. number (high part) (default 0)	
SM175	1175	Parameter 4 min. number (low part) (default 0)	
		These double words indicate the number of the memory variable to which refer the min. values for the input of the parameter field visualized on display.	R/W

SM125	1125	Parameter 1 max. area number (default 0) (default 0)	
SM142	1142	Parameter 2 max. area number (default 0) (default 0)	
SM159	1159	Parameter 3 max. area number (default 0) (default 0)	
SM176	1176	Parameter 4 max. area number (default 0) (default 0)	
		These words indicate the memory area to which refer the max. limits of the parameter fields visualized on display. Refer to SM107 for the complete list of variable areas.	R/W
SM126	1126	Parameter 1 max. number (high part) (default 0)	
SM127	1127	Parameter 1 max. number (low part) (default 0)	
SM143	1143	Parameter 2 max. number (high part) (default 0)	
SM144	1144	Parameter 2 max. number (low part) (default 0)	
SM160	1160	Parameter 3 max. number (high part) (default 0)	
SM161	1161	Parameter 3 max. number (low part) (default 0)	
SM177	1177	Parameter 4 max. number (high part) (default 0)	
SM178	1178	Parameter 4 max. number (low part) (default 0)	
		These double words indicate the number of the memory variable to which refer the max. values for the input of the parameter field visualized on display.	R/W
SM128	1128	Parameter 1 format (default 0)	
SM145	1145	Parameter 2 format (default 0)	
SM162	1162	Parameter 3 format (default 0)	
SM179	1179	Parameter 4 format (default 0)	
		These words define, for each of the 4 parameter fields, the type of data to be processed for the visualization and the input by terminal. They can take this values: 0 → 16 bit with sign 1 → 16 bit without sign 2 → 32 bit with sign	R/W
SM129	1129	Parameter 1 field total digits (default 1)	
SM146	1146	Parameter 2 field total digits (default 1)	
SM163	1163	Parameter 3 field total digits (default 1)	
SM180	1180	Parameter 4 field total digits (default 1)	
		These words define, for each of the 4 parameter fields, the tot. number of digits to be visualized on the numeric field. Allowed values 1÷12.	R/W

SM130	1130	Parameter 1 field decimal digits (default 0)	
SM147	1147	Parameter 2 field decimal digits (default 0)	
SM164	1164	Parameter 3 field decimal digits (default 0)	
SM181	1181	Parameter 4 field decimal digits (default 0)	
		These words define, for each of the 4 parameter fields, the tot. number of digits to be visualized on the numeric field. Allowed values 1÷10.	R/W
SM131	1131	Parameter 1 field filling type (default 0)	
SM148	1148	Parameter 2 field filling type (default 0)	
SM165	1165	Parameter 3 field filling type (default 0)	
SM182	1182	Parameter 4 field filling type (default 0)	
		These words define, for each of the 4 parameter fields, the type of filling for the unused digits to the left of the numeric field. Allowed values 1÷10. 0 → Space 1 → Zero	R/W
SM132	1132	Parameter 1 position line (default 2)	
SM149	1149	Parameter 2 position line (default 4)	
SM166	1166	Parameter 3 position line (default 6)	
SM183	1183	Parameter 4 position line (default 8)	
		These words define, for each of the 4 parameter fields, the line on display where the numeric field will be visualized. Allowed values 1÷8.	R/W
SM133	1133	Parameter 1 position column (default 15)	
SM150	1150	Parameter 2 position column (default 15)	
SM167	1167	Parameter 3 position column (default 15)	
SM184	1184	Parameter 4 position column (default 15)	
		These words define, for each of the 4 parameter fields, the column on display where the numeric field will be visualized. The column value indicates the starting point of the field which will expand as "Total digits" to the right. Allowed values 1÷8.	R/W

SM134	1134	Parameter 1 access type (default 0)	
SM151	1151	Parameter 2 access type (default 0)	
SM168	1168	Parameter 3 access type (default 0)	
SM185	1185	Parameter 4 access type (default 0)	
		<p>These words define, for each of the 4 parameter fields, the access type for the fields enabled to modification. For the fields with free access the input is always enabled, while for those protected by password the input is enabled only after entering password "1234".</p> <p>0 → Free 1 → Protected by password</p>	R/W



2.1.3 Memory area "digital inputs I"

This memory area "digital inputs I" is the area in which the state of digital inputs is stored. It is organized in words; each of the 16 bits of the word represents the state of an input. For instance: the state of digital input I20 is stored on bit no. 3 of word 2 in area I. The area consists of 16 words. The first and the second are updated with actual state of inputs at the starting of each cycle, while the last two words may contain the state of inputs read via serial communication from an expansion module.

2.1.4 Memory area "digital outputs Q"

This memory area stores status of digital outputs. It is organized in words; each of the 16 bits of the word represents the status of an output. Ex.: the status of digital output Q1 is stored on bit no. 0 of word 1 into the area Q. The area consists of 16 words. The first one is transferred to the outputs of PL110 at the end of each cycle, the other ones may contain the status of further outputs to write via serial communication to an expansion module.

2.1.5 Memory area "support marker M"

Memory area M contains the status of all markers (bit contacts) used into the program. It is organized in words; each of 16 bits of the word means the status of a marker. Ex.: status of marker M1 is stored on bit no. 0 of word 1 in the area M. The area is composed of 8 words.

2.1.6 Memory area "analogue inputs AI"

Into this memory area the PL110 stores the value which is measured on the analogue inputs. This value is calculated according to min. and max. limits which have been set as the range of the analogue input.

2.1.7 Memory area "analogue outputs AQ"

Memory area "analogue outputs AQ" is the memory where values for analogue outputs are assigned. The percentage of analogue output will be calculated starting from the entered value considering the range (min and max) of analogue output.

2.1.8 Memory area "timer T"

This memory area contains timer values. If timer is enabled, the value contained into this area will increase or decrease according to the type of timer, with the resolution chosen at the starting of timer.

2.1.9 Memory area "preset timer PT"

Memory area "preset timer PT" is the memory where preset values of timers are stored.

2.1.10 Memory area "counters C"

This memory area contains counters values. Accordingly to the type of counter, at each counting operation, the value contained into this area will be updated.

2.1.11 Memory area preset values of counters PV

In this area are stored the preset values of counters PV.

2.1.12 Memory area EEPROM

EEPROM area is the non-volatile memory to store all data which cannot be lost even if PLC is switched-off for long periods (over 6 months). Data stored in this area is tested at the starting of the PLC to check its integrity and in case of anomaly, the fault condition is notified (SM1.2) and the whole area is initialized at 0 (zero). Access and writing in this area requires longer time than any other area, therefore it is recommended not to use this area for frequent access, but only at starting to copy the stored data , for example in area V , and then to use these for quick access, guaranteeing a faster program.

N.B.: EEPROM memory allows a max. number of writings for each location (warranted 1000000), after that data integrity is no longer assured; so it is necessary to avoid continuously writing into this memory area.

2.1.13 Memory area MMC

MMC area is the optional external memory which can be used to save big amounts of data which must be stored even by lack of power supply. Memory is Eeprom, therefore access to this area is slower than access to area V and SM. PL110 does not check integrity of data saved in this area. This area is divided in words (0÷12999) and can also be entered by Modbus protocol.

N.B.: MMC memory allows a max. number of writings for each location (warranted 1000000), after that data integrity is no longer assured; so it is necessary to avoid continuously writing into this memory area.

2.1.14 Memory areas COMx_Tx and EXP1_Tx

Memory areas COMx_Tx and EXP1_Tx are used to load data which will be sent to the relevant serial port. They are used only in mode free-port. In standard mode these areas are handled with the selected communication protocol.

These areas are divided in byte (8 bit).

2.1.15 Memory areas COMx_Rx and EXP1_Rx

Memory areas COMx_Rx and EXP1_Rx are used to save data received by the relevant serial port. They are used only in mode free-port. In standard mode these areas are handled with the selected communication protocol.

These areas are divided in byte (8 bit).

2.1.16 Memory area display digits

The memory area DISP concerns only PL110-2A which is provided with keys and OLED display. The texts to be visualized on the available user pages must be stored into this area. The display is organized in 8 lines, each composed of 21 characters. The display characters area will be composed of $8 * 21 = 168$ characters, from 0 to 167.

This area is organized in byte (8 bits).

The picture below shows the correspondence between the display characters area and the display.

	COLUMN 1																	COLUMN 21
DISP 0																		DISP 20
DISP 21																		DISP 41
DISP 42																		DISP 62
DISP 63																		DISP 83
DISP 84																		DISP 104
DISP 105																		DISP 125
DISP 126																		DISP 146
DISP 147																		DISP 167

To cancel all the display areas, enter this coil on the ladder program:

BLKMOV (DISP0 = #32, N°Dati 168)

This allows to fill with the ascii character 32 (=space) all the display characters areas.

Ex. To write "DISPLAY TEXT" on the line no. 3 of the display, enter this coil on the ladder program:

MOVTEXT (DISP42, 1 Char per word) "TESTO DISPLAY"

3 Modbus RTU communication

3.1 Modbus RTU slave communication protocol

Module PL110 is conceived for application with SCADA systems or Operator panels via Modbus protocol RTU. Serial communication enables reading and modifying of data on available memory areas, entering and visualizing any data concerning the PLC. Module PL110 is provided with 3 serialcommunication ports which are enabled to operate as slaves with MODBUS protocol:

COM1 - RS485 available on pins 19, 20 and 21.

EXP1 – RS485 available on pins 21, 22 and 23.

COM2 – USB VCP (virtual serial port) available on USB connector.

Both serials support protocol modbus RTU as described below. Therefore the module PL110 may be connected and may communicate with 3 master devices at the same time.

Modbus RTU main features	
Baud-rate	Programmable
Format	8,N,1 (8 bit, no parity, 1 stop) (default)
Supported functions	BITS READING (0x01, 0x02)
	WORDS READING (max 30 word) (0x03, 0x04)
	SINGLE BIT WRITING (0x05)
	SINGLE WORD WRITING (0x06)
	MULTIPLE BITS WRITING (0x0F)
	MULTIPLE WORDS WRITING (max 30 word) (0x10)
Error codes	ILLEGAL FUNCTION CODE (0x01)
	ILLEGAL DATA ADDRESS (0x02)
	ILLEGAL DATA VALUE (0x04)
Broadcast	Simultaneous writing to all connected slaves using address 0x00 and no answer by slaves.
Polling with unknown slave address	Polling using address 0xFF, any connected slave can answer.

3.2 Addresses word/bit of PL110 for protocol Modbus RTU

The following tables give all data (word and bit) which may be entered via Modbus protocol. For all data the table gives reading/writing elements and the value assumed at starting of PL110. According to initialization value at starting, the following options are given:

“**ROM**” fixed value defined by program.

“**EEP**” value stored on Eeprom for 10years even in absence of power supply

“**TAMP**” value stored on Ram memory with buffer battery. These data are stored in absence of power supply for a limited time (approx. 4 months)

“?” value of these data is unknown at starting

Defined value, The value assumed at starting is the value defined in the table.

WORD			
MODBUS ADDRESS	DESCRIPTION	READ/ WRITE	RESET VALUE
0	Device type	R	ROM
1	PL110 program software version	R	ROM
2	Protocol activated on COM1	R	ROM
3	Protocol activated on EXP1	R	ROM
4	Protocol activated on COM2	R	ROM
5	Protocol address	R	TAMP
1000 ÷ 1099	Word area special marker SM	R/W	TAMP
2000 ÷ 2349	Word area variables V	R/W	TAMP
12000 ÷ 12047	Word area timer T	R/W	0
13000 ÷ 13047	Word area preset timer PT	R/W	0
14000 ÷ 14015	Word area counters C	R/W	0
15000 ÷ 15015	Word area preset counters PV	R/W	0
19000 ÷ 19065	Word area analogue inputs AI	R	0
19400 ÷ 19463	Word area analogue outputs AQ	R/W	0
20000 ÷ 20999	Word area EEPROM	R/W	EEP

WORD			
MODBUS ADDRESS	DESCRIPTION	READ/ WRITE	RESET VALUE
19800 ÷ 19815	Word % prop/integr/deriv/outputs PID	R	0 TAMP TAMP TAMP 0 ...
19800	% proportional action PID1		
19801	% integral action PID1		
19802	% derivative action PID1		
19803	% output PID1		
19804	% proportional action PID2		
19805	...		
19815	% output PID4		TAMP
30000 ÷ 42999	Word area MMC	R/W	EEP

AlltronicsPerú
AUTOMATIZACIÓN INDUSTRIAL

WORD			
MODBUS ADDRESS	DESCRIPTION	READ/ WRITE	RESET VALUE
100	N.O. contacts digital inputs I1÷I16	R	?
101	N.O. contacts digital inputs I17÷I32	R	?
102	N.O. contacts digital inputs I33÷I48	R	?
103	N.O. contacts digital inputs I49÷I64	R	?
104	N.O. contacts digital inputs I65÷I80	R	?
105	N.O. contacts digital inputs I81÷I96	R	?
106	N.O. contacts digital inputs I97÷I112	R	?
107	N.O. contacts digital inputs I113÷I128	R	?
108	N.O. contacts digital inputs I129÷I144	R	?
109	N.O. contacts digital inputs I145÷I160	R	?
110	N.O. contacts digital inputs I161÷I176	R	?
111	N.O. contacts digital inputs I177÷I192	R	?
112	N.O. contacts digital inputs I193÷I208	R	?
113	N.O. contacts digital inputs I209÷I224	R	?
114	N.O. contacts digital inputs I225÷I240	R	?
115	N.O. contacts digital inputs I241÷I256	R	?
150	N.O. contacts digital outputs Q1÷Q16	R/W	0
151	N.O. contacts digital outputs Q17÷Q32	R/W	0
152	N.O. contacts digital outputs Q33÷Q48	R/W	0
153	N.O. contacts digital outputs Q49÷Q64	R/W	0
154	N.O. contacts digital outputs Q65÷Q80	R/W	0
155	N.O. contacts digital outputs Q81÷Q96	R/W	0
156	N.O. contacts digital outputs Q97÷Q112	R/W	0
157	N.O. contacts digital outputs Q113÷Q128	R/W	0
158	N.O. contacts digital outputs Q129÷Q144	R/W	0
159	N.O. contacts digital outputs Q145÷Q160	R/W	0
160	N.O. contacts digital outputs Q161÷Q176	R/W	0
161	N.O. contacts digital outputs Q177÷Q192	R/W	0
162	N.O. contacts digital outputs Q193÷Q208	R/W	0
163	N.O. contacts digital outputs Q209÷Q224	R/W	0
164	N.O. contacts digital outputs Q225÷Q240	R/W	0
165	N.O. contacts digital outputs Q241÷Q256	R/W	0
200	N.O. contacts bistable relays B1÷B16	R/W	0
201	N.O. contacts bistable relays B17÷B32	R/W	0
300	N.O. contacts timer T1÷T16	R	0
301	N.O. contacts timer T17÷T32	R	0
302	N.O. contacts timer T33÷T48	R	0
350	N.O. contacts counters C1÷C16	R	0

WORD			
MODBUS ADDRESS	DESCRIPTION	READ/ WRITE	RESET VALUE
90	N.O. contact positioning on/off POS1÷POS2	R	0
95	N.O. contact tuning positioning on/off POS1÷POS2	R	0
250	N.O. contact support marker M1÷M16	R/W	0
251	N.O. contact support marker M17÷M32	R/W	0
252	N.O. contact support marker M33÷M48	R/W	0
253	N.O. contact support marker M49÷M64	R/W	0
254	N.O. contact support marker M65÷M80	R/W	0
255	N.O. contact support marker M81÷M96	R/W	0
256	N.O. contact support marker M97÷M112	R/W	0
257	N.O. contact support marker M113÷M128	R/W	0



BIT			
MODBUS ADDRESS	DESCRIPTION	READ/ WRITE	RESET VALUE
1600 ÷ 1855	N.O. contact digital input I1 ÷ N.O. contact digital input I256	R/W	?
2400 ÷ 2655	N.O. contact digital output Q1 ÷ N.O. contact digital output Q256	R/W	0
3200 ÷ 3231	N.O. contact bistable relay B1 ÷ N.O. contact bistable relay B32	R/W	0
4800 ÷ 4847	N.O. contact timer T1 ÷ N.O. contact timer T48	R	0
5600 ÷ 5615	N.O. contact counter C1 ÷ N.O. contact counter C16	R	0
1440 ÷ 1441	N.O. contact positioning on/off POS1 ÷ N.O. contact positioning on/off POS2	R	0
1520 ÷ 1521	N.O. contact tuning Positioning on/off POS1 ÷ N.O. contact tuning Positioning on/off POS2	R	0
4000 ÷ 4127	N.O. contact support marker M1 ÷ N.O. contact support marker M128	R/W	0
32000 ÷ 37599	Bit 0 area marker V0 ÷ Bit 15 area marker V249	R/W	TAMP
16000 ÷ 18079	Bit 0 area special marker SM0 ÷ Bit 15 area special marker SM129	R/W	TAMP

4 PL110 Ladder programming

4.1 Introduction

The software tool "PLProg" for Windows allows programming the module PL110. The ladder programming enables drawing the logic diagram of the application and uploading it to the PLC.

4.2 Elements of Ladder programming

Available elements with relevant features, to create the ladder diagram, are listed below.

4.2.1 Contacts digital inputs I

Contacts I contains the state of digital inputs of PL110 and of one more expansion module. The N.O. contact is closed (on) when bit value is 1 (active input). The N.C. contact is open (on) when bit value is 0 (input not active).

4.2.2 Digital outputs Q

PL110 is provided with 256 outputs type "Q", each composed of one coil and the relevant logic contact N.O. and N.C. which may be used to draw the ladder diagram. On PL110 hardware only 16 static outputs Q are physically available, the other ones are available as auxiliary outputs or on expansion module (if present).

Energizing coil "Q", the relevant logic contact will close (N.O.) or open (N.C.). The contacts of physical outputs are all N.O. and at starting all contacts N.O. are open.

4.2.3 Bistable relays B

32 bistable relays are available on PL110. Each consists of one coil and the relevant logic contact N.O. and N.C. .

Energizing coil “B”, the relevant logic contact will change its state (it opens if previously closed, it closes if previously open). The N.O. contact is closed (on) when bit value is 1. The N.C. contact is open (on) when bit value is 0. At starting of PLC the N.O. contact is open.

4.2.4 Timer T

Three different operating modes are available for timers:

- **TON.** Mode **Start timing as delay at activation** counts time when coil is active (ON). Timing bit (contact T) is activated when actual value (T) is equal or higher than preset time (PT). When coil is deactivated (OFF), actual value of timer is reset. Timer keeps on counting after reaching preset value and it stops reaching the max. value 32767.
- **TOFF.** Mode **Start timing as delay at deactivation** allows to delay the deactivation of an output for a certain time after the input has been deactivated. When the coil is activated, the timing bit (contact T) is immediately activated and the actual value (T) is set to zero. At deactivation of coil, the timer counts until elapsed time is equals to preset timer (PT). After reaching the preset timer, timing bit is deactivated and actual value does not increase. If input is deactivated for a time which is lower than preset time, the timing bit is still active. To start counting, the function TOF must notice a transition from activated to deactivated (ON → OFF).
- **TONR.** Mode **Start timing as delay at activation with memory** counts time when coil is activated (ON). Timing bit (contact T) is activated when actual value (T) is bigger or equals to preset time (PT). When coil is deactivated (OFF), actual value of timer “delay at insertion with memory” is stored. This value allows to accumulate time for more activation periods of the coil. Actual value of timer can be reset with operation MOV(Tx = #0). Timer keeps on counting after reaching preset value and it stops reaching the max. value 32767.

Timers with operating modes TON, TONR and TOF are available in three different resolutions, not depending from number of timer; they can be activated with time basis 10 ms, 100ms and 1s. Each counting of actual value is multiple of time base. Example a counting of 50 in a timer with time base 10 ms is equals to 500 ms.

Preset time (PT) can be directly loaded with a value or by means of a variable in the area VW, SMW, AI , TR.

4.2.5 Counter C

Counters are available with two operating modes:

- **MUP.** In mode **Count Up** the counting bit (contact C) is activated when present value (C) is \geq to preset value (PV). Counter counts up every time that the counting-up input Cx(UP) goes from Off to On and it counts down every time that the counting-down inputs Cx(DOWN) goes from Off to On.
The counter is reset when the reset input Cx(RESET) is activated or when the operation MOV(Cx = #0) is executed. At reaching of max. value (32.767), the next edge-up of the counting-up input will keep unchanged the actual value. Similarly at reaching of minimum value (-32.768) the next edge-up of the counting-down input will keep unchanged the actual value.
The onwards counters have a current value which keeps the current count (T). They have also a pre-selected value (PV) which is compared to the current value at the end of each program cycle. If the current value is greater or equal to the pre-selected value, the counting bit activates (contact C), otherwise it deactivates. Use the counter number to refer both to the current value of contact C and to the counter.
- **MDOWN.** In mode **Count Down**, the counting bit (contact C) is activated when present value is equals to zero. The counter counts down starting from a preset value (PV) on the edge-up of the countingdown input Cx(DOWN) and it counts up on the edge-up of the counting-up input Cx(UP). At reaching of max. value (32.767), the next edge-up of the counting-up input will keep unchanged the present value. The counter resets the counting bit (contact C) and load present value with preset value (PV) when loading input Cx(RESET) is activated. The counter in mode count-down stops counting when it reaches zero. Please use number of counter to refer both to actual value and to Contact C of the counter itself.

Preset value (PV) may be directly loaded with a value or it may be loaded

by one the variables in the area VW, SMW, AI, TR.

4.2.6 Mathematical formule FM function

The function FM allows to perform math operations (+, -, *, /, |, &, ^, <<, >>) between two operators and to save the result in another memory location. The operators can be numeric or they may also refers to available memory areas.

4.2.7 Assigement function MOV

The function MOV allows to assign to the specified memory location a numeric value or a value assumed by another memory location.

4.2.8 Assigement function BLKMOV

The function BLKMOV allows to assign to the memory block a numeric value or the value assumed by another block of memory locations.

4.2.9 Indexed Assigement Function MOVIND

The indexed assignment function MOVIND allows to assign to a certain memory location specified by another memory location a numeric value or the value assumed by another memory location selected in the area specified by a memory location which is the index. This type of assignment allows to consider the memory areas as vectors of a certain number of locations: by means of the value assumed by another location called "index" it is possible to enter the value of the area $n=0, n=1, \dots, n=N-1$.

4.2.10 Assigement function MOVTXT

Starting with the specified memory location, the assignment function MOVTXT allows to save the characters of a string sent as parameter to the function. Following types of format are available for characters of string in the memory area:

- **ONE_CHARACTER_PER_WORD**: in this format each word of destination area will contain **only one character of string**
- **TWO_CHARACTERS_PER_WORD**: in this format each word of destination area will contain two characters of string, starting with high

area of the word.

4.2.11 Contacts II immediate digital inputs

Contacts II allow to read immediately the state of digital input. The N.O. contact is closed (On) when bit value is 1 (active input). The N.C. contact is open (On) when bit value is 0 (deactivated input).

4.2.12 Immediate outputs QI

By means of direct access to outputs Q, PL110 allows to directly work on outputs Q during the ladder program execution, even without waiting the end of program. The command is allowed only on hardware outputs of PL110 (QI1..QI18).

4.2.13 IF contact

The operation "conditional comparison IF" allows to compare the values of variables in any memory area. Following comparisons are allowed: =, >=, <=, >, <, <>. Contact is active when comparison is true.

4.2.14 Funzioni SBIT e RBIT

SBIT function, bring to "1" a bit of a memory area, while the coil of the function is active.

RBIT function, bring to "0" a bit of a memory area, while the coil of the function is active.

Number of bit changes from 0 to 15, where bit 0 is the less significant bit (LSB).

4.2.15 BIT contact

This operation brings the value of a memory area bit. Contact normally open is closed (off) when the bit is 1. The contact normally closed is open (on) when the bit is 0. Number of bit changes from 0 to 15, where bit 0 is the less significant bit (LSB).

4.2.16 RANGE function

The RANGE function defines minimum and maximum limits for analogue inputs AI, for trimmer TR, for analogue outputs AQ and for PID outputs.

Concerning analogue inputs AI and trimmer TR, the minimum and maximum values allow to translate the counts value of the analogue-digital conversion into a value which can be used inside the program. Below an example:

RANGE(AI1, Min 10, Max 200)

For analogue input AI1 the function defines the minimum limit as 10 and the maximum limit as 200. In case that analogue input AI1 would be connected to a potentiometer to fix a preset time (PT) of a timer with time-base 100ms, the result would be a variable time between 1.0 and 20.0 seconds, according to the position of potentiometer.

Concerning analogue outputs AQ, minimum and maximum value allow to rate the effective tension value of output 0÷10V. Below an example:

RANGE(AQ1, Min -200, Max 500)

For analogue output AQ1 the minimum limit is fixed as -200 and the maximum limit is fixed as 500. This means that setting numeric value of output as -200, the output AQ1 will be 0 Volt while setting the numeric value as 500 the output AQ1 will be 10Volt. In case that entered value are not included in the interval specified by function RANGE, the output is kept within minimum and maximum values. For intermediate values, output tension is rated according to following formula:

$$\text{Output(volt)} = ((\text{Value} - \text{Min}) * 10) / (\text{Max} - \text{Min})$$

Maximum resolution for output AQ1 and AQ2 is 8 bit.

Concerning PID outputs, minimum and maximum values allow to rate the value for the output of PID control algorithm. Below an example:

RANGE(PID1, Min 100, Max 500)

For PID1 output , minimum limit is fixed as 0 and maximum limit is 500. This means that for output 0% the PID output will be equals to minimum fixed value and for output 100% the PID output will be equals to maximum fixed value. For each PID [1..8], minimum and maximum values of output are initialized at starting as 0 and 10000.

4.2.17 Contact NOT

The contact NOT modifies the current flow status. The current flow stops when reaching the contact NOT and gives power if cannot reach it. The operation NOT modifies logic value from 0 to 1 or from 1 to 0.

4.2.18 Contact P and N

The contact “positive transition P” activates the current flow for a single scanning cycle at each transition Off / On. The contact “negative transition N” activates the current flow for a single scanning cycle at each transition On / Off. When the operation “positive transition P” detects a transition of logic value from 0 to 1, it sets this value to 1, otherwise to 0. When the operation “negative transition N” detects a transition of logic value from 1 to 0, it sets this value to 1, otherwise to 0.

4.2.19 Function SEND and mode Free-port

Function SEND allows to activate data transmission by means of serial ports in mode free-port. In this mode, which can be activated by special marker SM32, SM33 and SM34, the protocol which usually handles the serial ports is disabled and the ports, as well as the relevant TX and RX buffers, are controlled by the ladder program. After loading on buffer the data to send and activating function SEND (which uses serial port and no. of characters to send as parameters) these data will be sent on serial line. During the transmission of data, bit SM0.7, SM0.7 or SM0.8 (according to transmission port) will be set to “1”, while it will be set to “0” at the end of transmission. It is possible to check the answer of a connected device by means of SM35, SM36 and SM37, which contain the number of characters received and saved on RX buffer of each serial port. Any writing on each of these special marker will empty the RX buffer. Calls to function SEND before the end of previous transmission or with mode free-port disabled will be ignored by the program.

4.2.20 Function TunePOS and POS (positioning axis ON/OFF)

Function "TunePOS" completes the autotuning which is necessary to rate reaction time and inactivity time of the axis on which a positioning procedure is required. The function "POS" proceeds to the ON/OFF positioning of an axis. Both functions operate on the same memory area with double word access (area marker VD); the start address of the used memory area is required as parameter by functions "TunePOS" and "POS". The following table shows how data is organized in the memory area used by the two functions, starting from the address of specified location.

Indirizzo area VD	Contents
+0	Encoder counts
+2	Counts setpoint value of positioning
+4	Counts maximum positioning error
+6	Time required to reach max. speed (tenth of seconds)
+8	Status of positioning output (0=stop, 1=onwards, - 1=backwards)
+10	Counts of inertia onwards
+12	Counts of inertia backwards
+14	Duration minimum impulse (resolution 0.2 mS)
+16	Counts of displacement after impulse of 100 mS
+18	Counts of displacement after impulse of 500 mS
+20	Counts of displacement after impulse of 1000 mS

To use these functions, proceed as follows:

- Use ladder instruction "MOV" to transfer the counting of used encoder (SMD20 = Encoder 1, SMD22 = Encoder 2) in the field "Encoder counts".
- Enter the counts value for axis positioning in the field "Counts setpoint value of positioning"
- Enter the counts value of max. error allowed to positioning in the field "Counts maximum positioning error"
- Enter time value (as tenths of second) required for the axis to reach max. speed.
- Start function "TunePOS" and wait until contact "TunePOS no" closes to notify end of Autotuning procedure for axis. Data concerning inertia and reaction time are now automatically stored on the indicated memory area where they remain at disposal for function "POS".
- Disable function "TunePOS".
- Start function "POS". When the axis reaches the setpoint (except for

preset error), contact "POS no" will close to notify end of positioning.

- Activate the outputs ONWARDS and BACKWARDS reading value in the field "Output". If value of "Output" is given by functions "TunePOS" and "POS" as "1", the output ONWARDS must be activated; if it is "-1" the output BACKWARDS must be activated; if it is "0" no output must be activated.
- Set to zero the value of field "Output" when the functions "TunePOS" or "POS" are disabled, to avoid that output is still set as Onwards or Backwards.

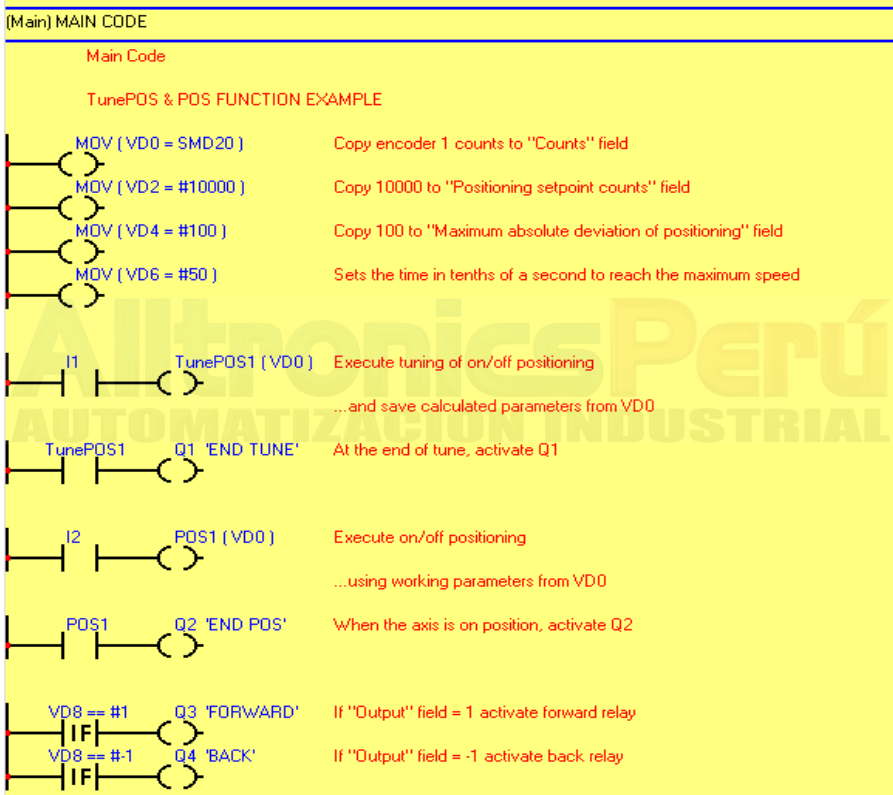

4.2.21 Function serial communication COM and EXP

Communication functions COM and EXP enable the programming of the serial ports (COM1-RS485 and EXP1-RS232) for reading/writing of data from connected slave devices using the master protocol selected in the project. These functions are active only when in the project a master communication protocol has been selected for the relevant serial port. A Master protocol means a protocol which enables the PL110 to control the serial line communication, controlling the data flow towards slave devices. The two functions are similar, they only refer to a different serial port. Instruction COM operates with interface RS485, allowing to connect more devices on the same line, while instruction EXP operates with interface RS232 allowing to connect one single device to PL110. Instructions are active while the relevant coil is active. Consider also that, according to communication protocol, the time required for data update can be quite different and read data is not immediately available at activation of coil, but only after a certain time depending from communication delays. Instructions COM and EXP require the configuration of following parameters:

- Index (max. 16 different serial pollings)
- Type of operation:
 - Reading:** PL110 will read continuously data from slave device and will store them in an internal memory area.
 - Writing:** PL110 will write continuously data on an internal memory area of the slave device
 - Reading/Writing:** PL110 will read data on slave device and will store them in an internal memory area; when these internal data on PL110 will be modified by the program, any change will be automatically sent also to slave device by means of a writing instruction (this instruction can work only on a single data each time).
- Slave number (communication address of slave device)
- Data type (word or bit)
- Number of data (or starting number in case of more data)
- Internal memory area of PL110 where data must be read/written
- Word number (the same reading / writing instruction can work simultaneously on more consecutive data)

“NAIS MATSUSHITA-MASTER” PROTOCOL

This communication protocol allows to read/write data (bit or word) on a Nais - Matsushita plc. Generally, communication interface is a RS232 and communication format is 9600,8,O,1.

The following tables show all elements which can be read/written by the plc. The address bit or word to be read/write is obtained adding the real bit/word address (between Min and Max) to the value showed in the Offset column. Each instruction "COM" or "EXP" can execute reading/writing for each type of data which is indicated in the column "Max number of consecutive bit/word read/wrote".

ACCESS TO BIT						
Contact	Notation	Min	Max	Offset	R/W	Max number of consecutive bit read/wrote
External input	“X”	0	9999	0	R	8
External output	“Y”	0	9999	10000	R/W	8
Internal relay	“R”	0	9999	20000	R/W	8
Link relay	“L”	0	9999	30000	R/W	8
Timer	“T”	0	9999	40000	R	8
Counter	“C”	0	9999	50000	R	8

ACCESS TO WORD						
Data Code	Notation	Min	Max	Offset	R/W	Max number of consecutive word read/wrote
External input	“X”	0	999	0	R	10
External output	“Y”	0	999	1000	R/W	10(R) / 7(W)
Internal relay	“R”	0	999	2000	R/W	10(R) / 7(W)
Link relay	“L”	0	999	3000	R/W	10(R) / 7(W)
Timer	“T”	0	999	4000	R	10
Counter	“C”	0	999	5000	R	10
Index register X		0	0	6000	R/W	1
Index register Y		0	0	6001	R/W	1
Index register D		0	0	6002	R/W	1
Data register	“DT”	0	9999	10000	R/W	10(R) / 7(W)
Link data register	“LD”	0	9999	20000	R/W	10(R) / 7(W)
File register	“FL”	0	9999	30000	R/W	10(R) / 7(W)

Set value area		0	9999	40000	R/W	10(R) / 7(W)
Elapsed value area		0	9999	50000	R/W	10(R) / 7(W)

N.B.: On PL110-XX protocol, only elements underlined in grey are enabled (the other elements have not to be used!). The example below describes setting for an "EXP" instruction to write on the plc with "1" of 8 consecutive bit on "external output" Y3 and YA, taking value from VW10.

Parameters

Slave action and address

Write on SLAVE no. Min 0
Max 255

Address Word\Bit

Bit number Min 0
Max 65535

Area (Destination for reading Source for writing)

Memory area V word

Number of consecutive Word\Bit read\written

No. Word Min 0
Max 16

Following example describes the setting for an "EXP" instruction to read from the plc with address "1" of 10 consecutive bit from "data register" DT0 to DT9, keeping read value on area VW0..9.

Parameters

Slave action and address

Read on SLAVE no. Min 0
Max 255

Address Word\Bit

Word number Min 0
Max 65535

Area (Destination for reading Source for writing)

Memory area V word

Number of consecutive Word\Bit read\written

No. Word Min 0
Max 16

4.2.22 Functions StartPID , PID , SetOutPID

Functions StartPID, PID and SetOutPID enables control of a process by means of PID algorithm (proportional, integral, derivative).

Function StartPID starts the relevant control block and sets parameters as required. Function can be activated once at the starting or it may be recalled later to modify quickly control parameters. PID integral action is initialized only calling this function and setting integral time to 0, otherwise even in case of switch-off the system will start control action keeping the same percentage of integral action and consequently limiting the transient times. Parameters required by function StartPID are the following:

- Proportional band
- Integral time
- Derivative time
- Dead band

Parameters can be entered with numeric format or referring to internal variables. Integral time is expressed in time unit used for PID function (ex. PID function recalled every 1 sec., integral time expressed in seconds). Derivative time is expressed with one decimal digit more than integral time. Proportional band and dead band are expressed with a numeric value as setpoint and process.

PID function requires following parameters:

- Setpoint
- Process
- Output value
- Type of control action
- Type of output

After acquisition of necessary parameters values, PID function will enter the value obtained by control algorithm in the variable "Output value". This value will have been obtained rescheduling the percentage value 0 – 10000 (0.00% ÷ 100.00%) between minimum and maximum value of PID output as entered using the function RANGE.

For optimal results, PID function should be recalled at regular intervals. A timer can be used or even an internal Interrupt, to get shorter intervals.

Function SetOutPID is used for control actions which foresee both automatical and manual functions. The function allows to avoid process oscillations when changing from manual to automatical PID control. Following parameters are required:

- Output value

It allows to set the value of PID output, automatically rating the single percentages of proportional and integral action. Changing from manual to automatic operation, PID output will assume the value entered in manual function and it will start control action.

Consequently the function must be used only in manual control, to keep PID output in line with value of manual control.

This function automatically cancels derivative action.

If the function is used with process value outside proportional band, integral action will be set to 0.

4.2.24 Function GENSET

Function GENSET allows to generate automatically a variable setpoint, with option to enter an acceleration and deceleration ramp. Function GENSET operates on a series of adjoining variables in double word, starting with the location which is given as parameter of the function.

Indirizzo area VD	Contents
+0	State of function GENSET 0 → Stop or end motion 1 → Function initialization 2 → Acceleration ramp 3 → Motion at constant speed 4 → Deceleration ramp
+2	Starting Setpoint / Setpoint rated at end of GENSET function (counts)
+4	Final setpoint (counts)
+6	Motion speed (counts * 1000 / time units)
+8	Duration of acceleration ramp (time units)
+10	Duration of deceleration ramp (time units)
+12	Instant speed of setpoint (counts * 1000 / time units)

To use this function, proceed as follows:

- Enter on location VD+2 the starting setpoint
- Enter on location VD+4 the final setpoint
- Enter on location VD+6 max. motion speed as counts*1000/time units (to have 3 decimals. Example: setting 12345 will give a speed of 12.345 counts/time units)

- Enter on location VD+8 the duration of acceleration ramp (expressed as time units; if duration of acceleration ramp must be 1 second and function GENSET is recalled by an interrupt of 1 ms, enter 1000)
- Enter on location VD+10 the duration of deceleration ramp.
- Write "1" on location VD. to start the function which will automatically start to write on location VD+2 the generated setpoint. Location VD will also be updated with current state of function, while location VD+12 will be updated with instant speed of setpoint, expressed with 3 decimals. This value may be used to generate action "F" for function POSPID..

At end of motion, when location VD+2 will reach value of final setpoint, the function will automatically enter standby mode, indicated by value "0" on location VD. This means that function GENSET can be always active, even when motion is not required.



4.2.25 Function CONV

The function CONV provides the conversion of source data in one of the available formats. Conversion type "TO_7SEG_SIGNED" converts input data (one word with sign -32768..32767) in a specified number of digits already suitable for a display with 7 segments. The number of digits to convert, starting from less significant digit, will be sent to the function as parameter.

The codes will be saved (one digit for each word) starting from destination word and then in the following words according to the required number of digits.

Conversion type "TO_7SEG_UNSIGNED" is similar to the above described conversion. The difference is that the source data is considered as unsigned word (0..65535). The code is composed by one bit set to 1 if the segment must be ON and by one bit set to 0 if the segment must be Off. The correspondance between bit and segment is the following:

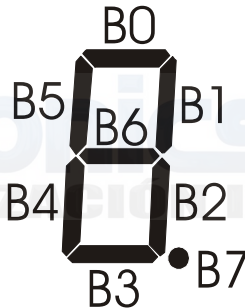

Conversion type "TO_ASCII_SIGNED" converts the entering data (one word with sign -32768..32767) in a specified number of ascii characters. The number of characters to save will be assigned to this function as parameter. Codes of these characters will be saved (one character per word) starting with the destination word and then in the following ones, according to the no. of required characters.

Conversion type "TO_ASCII_UNSIGNED" is similar to the one described above, but the source data is meant as unsigned word (0..65535).

4.2.26 Function SetPAR

The PL110-2A allows to select by ladder logic the visualization of some user pages (max. 16) in addition to the pre-selected system pages managed directly by the firmware. For each page it is possible to select the text to be visualized (using the display character area DISP) and up to a max. of 4 numeric fields which can be only in visualization or enabled to modification.

The SetPAR function allows to select one of the four numeric parameter fields to be visualized on display. Function parameters are:

- Number of field to which refer (1..4)
- Field status (disabled, visualized, modifiable)
- Variable related to the field
- Min. limit for the possible modification by keyboard
- Max. limit for the possible modification by keyboard

To not visualize the field it is necessary to select the status on disabled field, so the other parameters becomes not influential. If the field is only in visualization, min. and max. values becomes not influential.

4.2.27 Function FormatPAR

FormatPAR function, to be used in addition to the SetPAR function, allows to reset the numeric parameter field to be visualized on display. Function parameters are:

- Number of field to which refer (1..4)
- Type of data to be processed
- Tot. digits of numeric field
- Tot. decimal digits of numeric field
- Type of filling for unused digits (space or zero)

This function loses meaning when the parameter field is selected as disabled by the SetPAR function.

4.2.28 Function PosPAR

PosPAR function to be used in addition to the SetPAR and FormatPAR functions, allows to place the numeric parameter field to be visualized on display. Function parameters are:

- Number of field to which refer (1..4)

- Line of display from which the visualization starts (1..8)
- Column of display from which the visualization starts (1..21)
- Type of access if the parameter field is selected as not modifiable (free access or access protected by password "1234")

This function loses meaning when the parameter field is selected as disabled through the SetPAR function.





5 PL110-2A user interface terminal

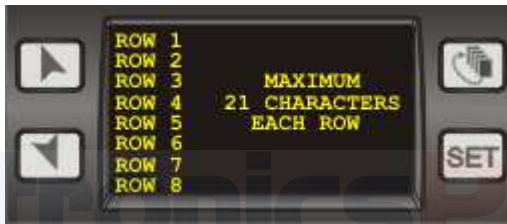

5.1 Introduction

The PL110-2A in addition to the management of inputs/outputs, integrates also a terminal with OLED display 128 x 64 and four keys to manage system pages, programmable user pages and the modification of some plc internal variables. Thanks to the ladder code created with PLProg it is possible to set pages, messages and fields to be visualized and modified.

5.2 Display and keyboard





KEY	FUNCTION
	"Swap" key allows to scroll through the pages which have been created by the ladder program. Available pages can be those of system and those defined during programming. Pressing "swap" it is possible to pass from the incremental modification to the modification with digit (useful when there are numbers with many digits). This option is enabled only when one parameter field has already been modified ("reverse" visualization).
KEY	FUNCTION
	SET key allows to modify the numeric fields on display. When modification is active, the numeric field is visualized in "reverse". If more fields in the page are enabled to modification, pressing SET it is possible to switch to the next field. Pressing SET for 2" it is possible to enter the page on which



	the password must be entered; the password can be used to avoid accidental modifications on input fields which can be modified only after entering the correct password.
	UP key allows to increase the value of the numeric field which is being entered. According to the enabled entering type (incremental or with digit) the key will increase of only one unit or of a value $1 \cdot 10^n$, where "n" corresponds to the number of digit enabled to the modification.
	DOWN key allows to decrease the value of the numeric field which is being entered. According to the enabled entering type (incremental or with digit) the key will decrease of only one unit or of a value $1 \cdot 10^n$, where "n" corresponds to the number of digit enabled to the modification.

AlltronicsPerú
AUTOMATIZACIÓN INDUSTRIAL

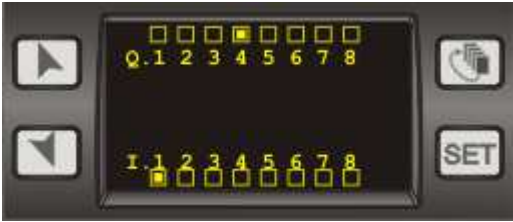
5.3 System pages description

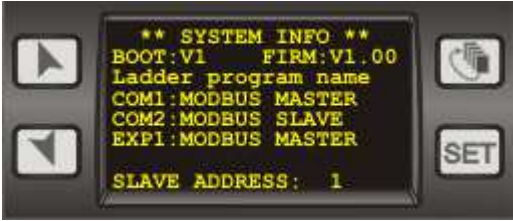
The following table shows available system pages.

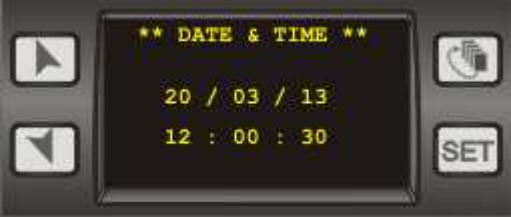
N°	PAGE / DESCRIPTION
1	 <p>This page visualizes status of the PLC digital I/O. Active I/O are indicated with a full square.</p>
2	 <p>This page visualizes the value of PLC analogue inputs.</p>
3	 <p>This page resumes some PLC system information such as: BOOT and firmware program version, name of the loaded ladder application, protocols related to serial ports, number of slave (necessary for serial communications with other master devices). This number can be modified only after entering password "1357".</p>

<p>4</p>	 <p>This page allows to visualize and modify date and hour of the PLC internal clock.</p>
<p>5</p>	 <p>This page allows to visualize and select two important parameters such as the standby brightness (low consumption or standby) and the standby delay. These parameters allow to reduce brightness or to switch-off the display after that keys haven't been pressed for some minutes, to avoid disturbing the environment with light and to improve the lifecycle of the OLED display.</p>

5.4 User pages description

The PLC can manage up to 16 user pages, to which the system assigns numbers from 17 to 32. Here below an example of program for the creation/management of 2 user pages, 17 and 18.

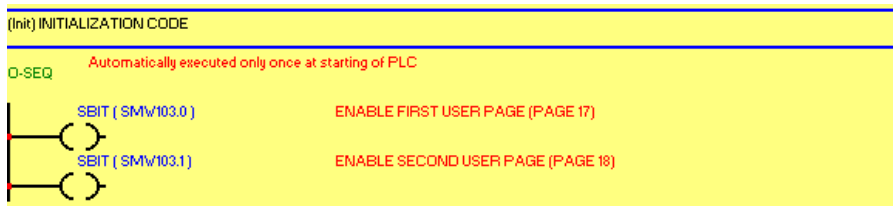

Into this section, selecting to "1" bits SMW103.0 and SMW103.1 the first 2 user pages (17 and 18) are enabled.

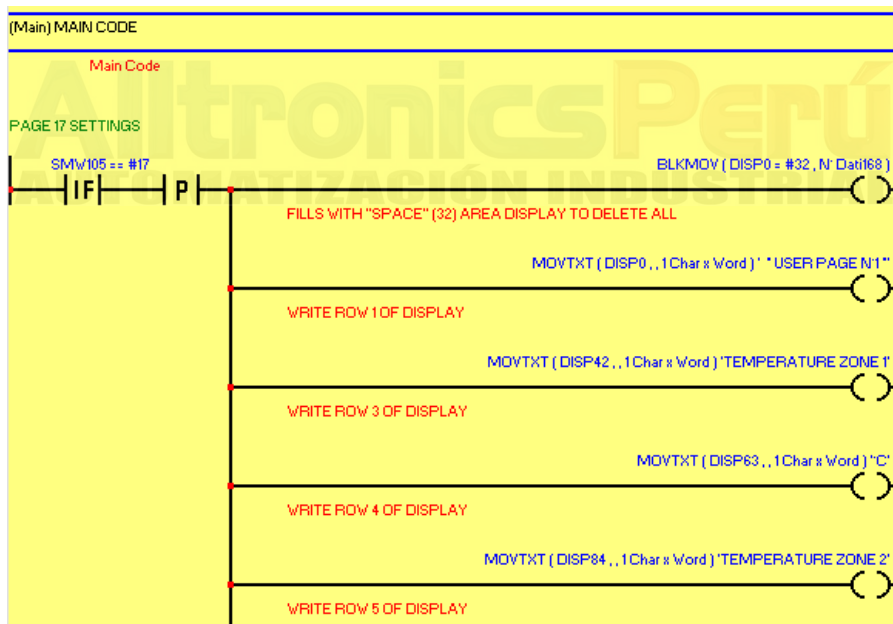

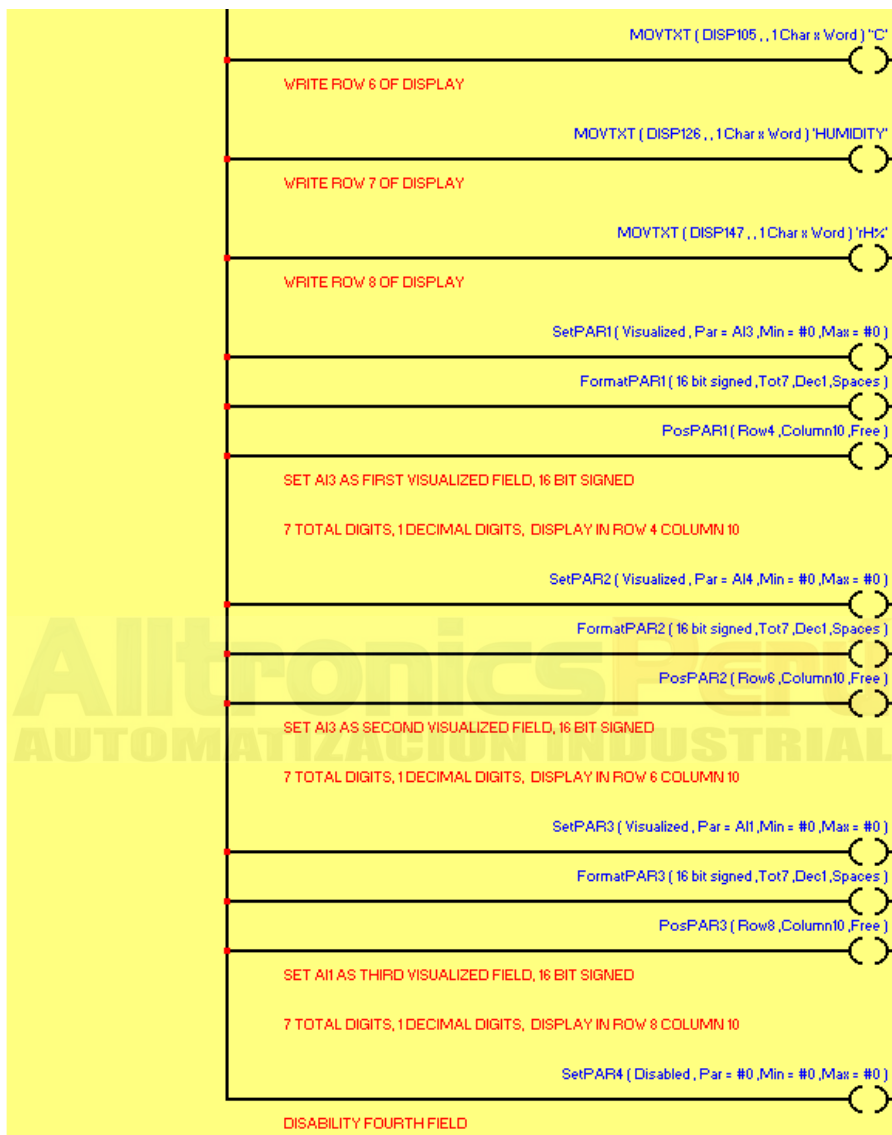

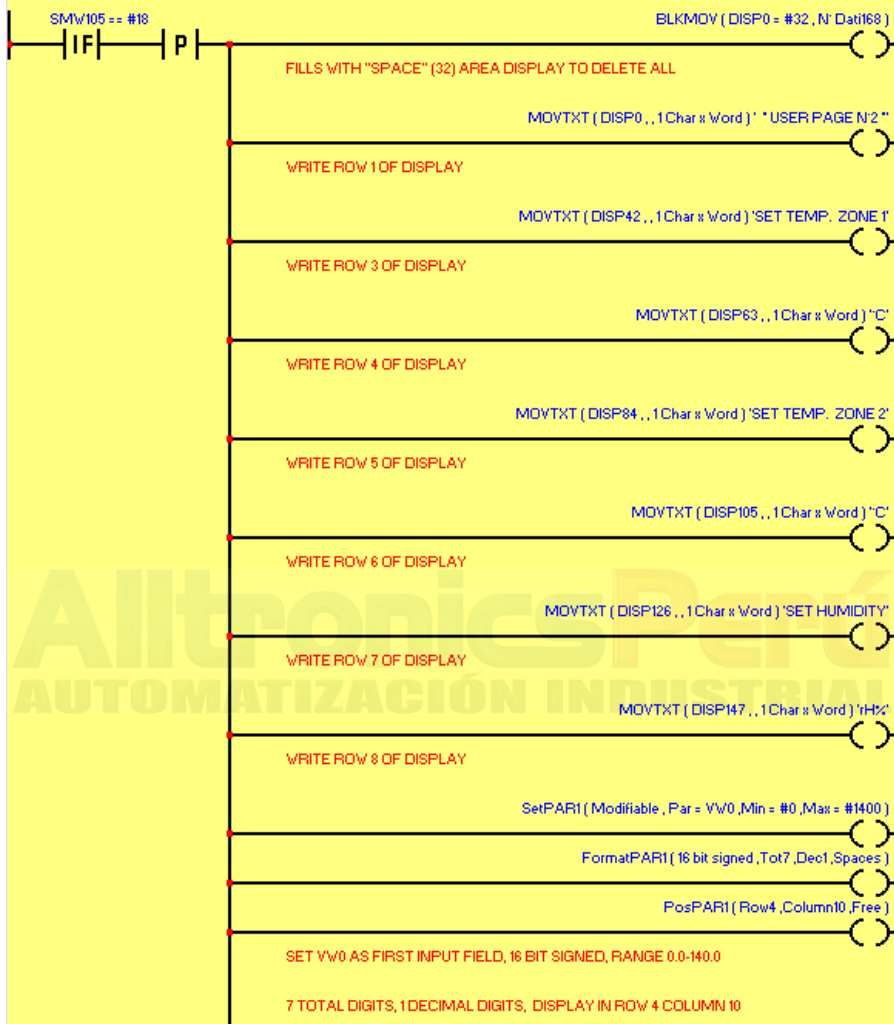

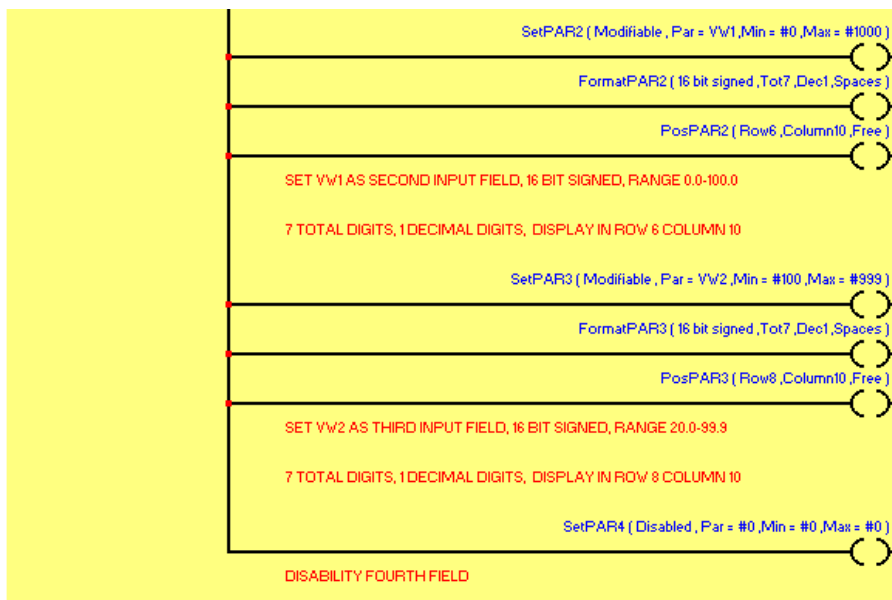

The following table shows the two pages created by the above-mentioned program.



N°	PAGE / DESCRIPTION
17	<div data-bbox="341 922 853 1145" data-label="Image"> </div> <p data-bbox="199 1182 994 1300">Page 17 is only for visualization and in addition to the text loaded on display characters area (DISP) it shows three numeric fields indicating the status of the PLC analogue inputs. The fourth field is disabled, so it is not visualized.</p>

N°	PAGE / DESCRIPTION
18	<div data-bbox="342 189 854 411" data-label="Image"> </div> <p data-bbox="202 448 997 600">In addition to the text loaded on display characters area (DISP), page 18 shows other 3 numeric fields enabled to modification, with the value of 3 PLC variables VW used as setpoint. The fourth field is disabled, so it is not visualized. Pressing SET it is possible to enable cycling modification of one field.</p>

5.5 Special pages description

The following table describes the special pages.

N°	PAGE / DESCRIPTION
253	<div data-bbox="342 951 854 1173" data-label="Image"> </div> <p data-bbox="202 1209 997 1316">This page can be entered pressing SET for 2". Through the arrows and the swap keys enter the password to access parameter modifications.</p>

N°	PAGE / DESCRIPTION
254	 <p>This page is visualized at starting if no valid ladder application is noticed on the PLC memory.</p>
255	 <p>This page is visualized during the connection with the PC for the PLC/memory card programming.</p>

Alltronics Perú

AUTOMATIZACIÓN INDUSTRIAL

Alltronics Perú

AUTOMATIZACIÓN INDUSTRIAL

PIXSYS
Via Po, 16
30030 Mellaredo di Pianiga (VE)
www.pixsys.net
e-mail: sales@pixsys.net - support@pixsys.net

Software Rev. 1.01 (firmware)

2300.10.179-RevA 090513

AlltronicsPerú
AUTOMATIZACIÓN INDUSTRIAL

Av. Argentina N° 523 Tda. A12 C. C. ACOPROM Lima 01 - Perú
Telfs.: 51+1+719 9810 / 51+1+719 9811 Cel.: 51+999938660 / 51+9852-72098
E-mail: ventas.1@alltronicsperu.com ventas.2@alltronicsperu.com
www.AlltronicsPerú.com