

N3 TECO AC Drive

- Sensorless Vector AC Drive
- PID Control with Sleep Mode
- Simple Full Featured Operator with Speed Potentiometer
- PC Programming Software
- RS485 Interface Option
- EEPROM Program Copy Unit
- .5 to 3 HP, 230V, 50/60 Hz, 1-Phase
- .5 to 40 HP, 230V, 50/60 Hz, 3-Phase
- 1 to 75 HP, 460V, 50/60 Hz, 3-Phase
- UL, cUL, and CE Approved



TECO  **Westinghouse**



Alltronics Perú
AUTOMATIZACIÓN INDUSTRIAL

DIMENSIONS AND WEIGHTS

230V 1-Phase Input / 3-Phase Output

MODEL NO.	HP CT	DRIVE AMPS CT	DIMENSIONS (Inches)			APPROX. WT. (lbs.)
			HEIGHT	WIDTH	DEPTH	
*N3-2P5-CS	.5	3.1	6.42	3.54	5.79	3
*N3-201-CS	1	4.5	6.42	3.54	5.79	3
*N3-202-CS	2	7.5	7.36	5.04	5.83	4
*N3-203-CS	3	10.5	7.36	5.04	5.83	5

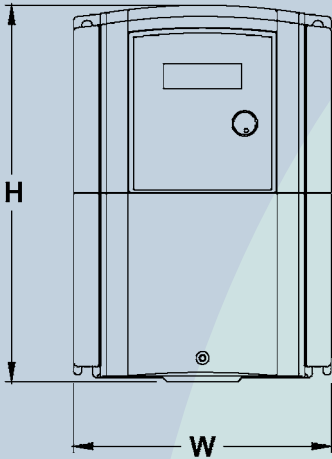

230V 3-Phase Input / 3-Phase Output***

MODEL NO.	HP CT	DRIVE AMPS CT	DIMENSIONS (Inches)			APPROX. WT. (lbs.)
			HEIGHT	WIDTH	DEPTH	
*N3-2P5-C	.5	3.1	6.42	3.54	5.79	3
*N3-201-C	1	4.5	6.42	3.54	5.79	3
*N3-202-C	2	7.5	6.42	3.54	5.79	3
*N3-203-C	3	10.5	7.36	5.04	5.83	4
*N3-205-C	5	17.5	7.36	5.04	5.83	5
*N3-207-C	7.5	26.0	10.24	7.32	7.68	13
*N3-210-C	10	35.0	10.24	7.32	7.68	13
*N3-215-N1	15	48.0	14.17	10.43	9.70	27
*N3-220-N1	20	64.0	14.17	10.43	9.70	27
N3-225-N1	25	80.0	14.17	10.43	9.70	29
**N3-230-N1	30	96.0	25.45	10.60	12.00	67
**N3-240-N1	40	130.0	25.45	10.60	12.00	67

460V 3-Phase Input / 3-Phase Output***

MODEL NO.	HP CT	DRIVE AMPS CT	DIMENSIONS (Inches)			APPROX. WT. (lbs.)
			HEIGHT	WIDTH	DEPTH	
*N3-401-C	1	2.3	6.42	3.54	5.79	3
*N3-402-C	2	3.8	6.42	3.54	5.79	3
*N3-403-C	3	5.2	7.36	5.04	5.83	4
*N3-405-C	5	8.8	7.36	5.04	5.83	4
*N3-407-C	7.5	13.0	10.24	7.32	7.68	13
*N3-410-C	10	17.5	10.24	7.32	7.68	13
*N3-415-C	15	25.0	10.24	7.32	7.68	13
*N3-420-N1	20	32.0	14.17	10.43	9.70	27
N3-425-N1	25	40.0	14.17	10.43	9.70	29
N3-430-N1	30	48.0	14.17	10.43	9.70	29
**N3-440-N1	40	64.0	25.45	10.60	12.00	67
**N3-450-N1	50	80.0	25.45	10.60	12.00	67
**N3-460-N1	60	96.0	29.39	12.13	15.20	102
**N3-475-N1	75	128.0	29.39	12.13	15.20	102

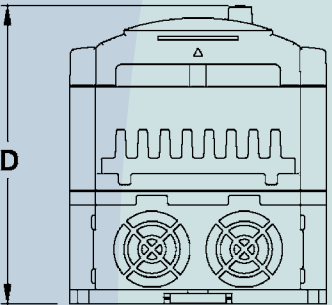

NOTE: Suffix CS = Chassis Unit 1-Phase
C = Chassis Unit 3-Phase
N1 = NEMA 1

All Chassis Units will Ship with NEMA 1 Boxes for Field Installation

- * Includes Dynamic Braking Transistor
- ** Includes DC Bus Link Reactor
- *** Do Not Apply Single Phase Input Power to these Models.

SPECIFICATIONS

Control Mode	Sensorless Vector and V/Hz
Input Voltage Rating	230V 1-Phase and 3-Phase; 460V 3-Phase
Input Voltage Tolerance	+10%, -15 Hz
Frequency Control Range	0 to 400 Hz
Speed Control Accuracy	+/- 0.5% (Sensorless Vector Mode)
Speed Commands	0 to 10VDC, 0 to 20mA, Pulse Input
Overload Capacity	150% Current of Drive Rating for 1 Minute
Braking	DC Injection Braking: Dynamic Braking (optional)
Protective Functions	Motor and Inverter Overload, Overvoltage, Overheating, Peak Overcurrent
Programmable I/O	7 Digital Inputs (NPN or PNP), 2 Relay Outputs
Ambient Temperature	-10°C to +50°C, (14°F to 122°F)
Enclosure	IP20 Protective Chassis/NEMA 1

TECO   **Westinghouse**

Av. Argentina N° 523 Tda. A12 C. C. ACOPROM Lima 01 - Perú
Telfs.: 719 9811 / 680 2668 / 711 9327 Cel.: 9852-72098 / 9999-38660
E-mail: ventas.1@alltronicsperu.com cotizador.1.1@alltronicsperu.com

www.AlltronicsPeru.com